

CAUTION

1. READ THIS MANUAL CAREFULLY TO
DIAGNOSE TROUBLE CORRECTLY
BEFORE OFFERING SERVICE.
2. THIS MANUAL IS USED BY QUALIFIED
APPLIANCE TECHNICIANS ONLY.
3. HAIER DOES NOT ASSUME ANY
RESPONSIBILITY FOR PROPERTY
DAMAGE OR PERSONAL INJURY FOR
IMPROPER SERVICE PROCEDURES
DONE BY ONE UNQUALIFIED PERSON.

TECHNICAL DATA

ON/OFF

Wall mounted Type K-Series

HSU-07LEK03
HSU-07HEK03
HSU-09LEK03
HSU-09HEK03
HSU-12LEK03
HSU-12HEK03



Большая библиотека технической документации

<https://splitsystema48.ru/instrukcii-po-ekspluatacii-kondicionerov.html>

каталоги, инструкции, сервисные мануалы, схемы.



Table of Contents

1. Features.....	2
2. Specifications.....	3
3. Remote controller lists.....	6
4. Sensors lists.....	6
5. Dimensional drawings.....	7
6. Operation range.....	8
7. Piping diagrams.....	9
8. Wiring diagrams.....	10
9. Capacity diagrams and curves diagrams.....	12
9.1 Cooling capacity-temperature curves.....	12
9.2 Heating capacity-temperature curves.....	14
9.3 Cooling power consumption value-temperature curves.....	16
9.4 Heating power consumption value-temperature curves.....	18
9.5 Cooling discharge pressure curves.....	20
9.6 Heating discharge pressure curves.....	22
9.7 Cooling suction pressure curves.....	24
9.8 Heating suction pressure curves.....	26
10. Sound level.....	28
11. Accessories.....	29
12. Control systems.....	30
13. Center of gravity.....	31
14. Installations.....	32

1 Features



ESF filter : Trap harmful dust and remove unpleasant odors effectively



4 Fan setting: Slect the fan speed LO,MED,HI,AUTO



Anti-mold filter: Catches most small particles and remove unpleasant odors effectively



Sleep mode: The setting temprature and the indoor noise can be adjusted to a more comfortable level when you set the "sleep mode"during night sleep



24 Hour timer: Use the timer function to set on,or off,or from on to off,or from off to on



Auto restart: The function permits automatic return to previous peration conditions



Easy clean design: The panel is easy to wash and the airflow vents can be detached without any special tools for quick cleaning of the inside of the air conditioner



Auto mode According to the fixed temperature "26°C " ,the unit will adjust the operation mode automatically.



2 Specifications

This information was not available at the time of publication .

NOMINAL CAPACITY and NOMINAL INPUT									
For indoor units only:									
INDOOR UNITS				HSU-07LEK03	HSU-07HEK03	HSU-09LEK03	HSU-09HEK03	HSU-12LEK03	HSU-12HEK03
NOMINAL INPUT	Cooling	nominal	KW	0.9	0.9	0.94	0.94	1.25	1.25
	Heating	nominal	KW	----	0.75	----	0.85	----	1.28

NOMINAL CAPACITY and NOMINAL INPUT										
Model				HSU-07LEK03	HSU-07HEK03	HSU-09LEK03	HSU-09HEK03	HSU-12LEK03	HSU-12HEK03	
NOMINAL CAPACITY(3-4)	Cooling(1)	norm.	kw	2.38	2.38	2.5	2.5	3.5	3.5	
	Heating(2)	norm.	kw	----	2.65	----	2.75	----	3.8	
NOMINAL INPUT	Cooling	norm.	kw	0.9	0.9	0.94	0.94	1.25	1.25	
	Heating	norm.	kw	----	0.75	----	0.85	----	1.28	
EER	Cooling			2.64	2.64	2.66	2.66	2.8	2.80	
COP	Heating			----	3.53	----	3.24	----	2.97	
ANNUAL ENERGY CONSUMPTION(9)	Cooling			kwh	450	450	470	470	625	625

TECHNICAL SPECIFICATIONS										
INDOOR UNITS				HSU-07LEK03	HSU-07HEK03	HSU-09LEK03	HSU-09HEK03	HSU-12LEK03	HSU-12HEK03	
DIMENSIONS	Unit	H	mm	182	182	182	182	182	182	
		W	mm	780	780	780	780	780	780	
		D	mm	260	260	260	260	260	260	
WEIGHT	Unit		kg	7.6	7.6	7.6	7.6	8.8	8.8	
COLOR	Unit			White	White	White	White	White	White	
SOUND LEVEL	Sound pressure (cooling/heating) (5)	high	dB(A)	37	37	37	37	39	39	
		medium	dB(A)	33	33	33	33	35	35	
		low	dB(A)	29	29	29	29	31	31	
FAN	Sound power (cooling/heating)(6)	high	dB(A)	37	37	37	37	39	39	
		Air flow rate (cooling/heating)	high	m ³ /min	6.67	6.67	6.67	6.67	9.17	9.17
			medium	m ³ /min	6.11	6.11	6.11	6.11	8.17	8.17
low	m ³ /min		5.56	5.56	5.56	5.56	7.10	7.10		
FAN	Speed (cooling/heating)	steps		3 steps, Auto						
		high	rpm	1200	1200	1200	1200	1290	1290	
		medium	rpm	1100	1100	1100	1100	1150	1150	
		low	rpm	1000	1000	1000	1000	1000	1000	
	Type		Cross flow fan							
Motor output		W	20	20	20	20	25	25		
HEAT EXCHANGER	Type		ML fin - Φ 7HI - XA tube							
	Row x stage x fin pitch		mm	2 x 2 x1.3	2 x 2 x1.3	2 x 2 x1.3	2 x 2 x1.3	2 x 3 x1.3	2 x 3 x1.3	
AIR FILTER	Removable/washable/mildew proof									
REMOTE CONTROLLER				YL-W01	YR-W01	YL-W01	YR-W01	YL-W01	YR-W01	
TEMPERATURE CONTROL	Microcomputer control									
PIPING CONNECTIONS (external diameter)	liquid	mm		Φ 6.35	Φ 6.35	Φ 6.35	Φ 6.35	Φ 6.35	Φ 6.35	
		gas	mm	Φ 9.52	Φ 9.52	Φ 9.52	Φ 9.52	Φ 12.7	Φ 12.7	
		drain	mm	Φ 16	Φ 16	Φ 16	Φ 16	Φ 16	Φ 16	
INSULATION MATERIAL	Heat insulation type			both liquid and gas pipes						

TECHNICAL SPECIFICATIONS									
OUTDOOR UNITS				HSU-07LEK03	HSU-07HEK03	HSU-09LEK03	HSU-09HEK03	HSU-12LEK03	HSU-12HEK03
NET DIMENSIONS (stop valve, and bottom support is not included)	Unit	H	mm	428	428	428	428	428	428
		W	mm	700	700	700	700	700	700
		D	mm	261	261	261	261	261	261
WEIGHT	Unit	kg	23.5	25.1	23.5	25.1	29.2	30.6	
COLOR	Unit		white	white	white	white	white	white	
SOUND LEVEL	Sound pressure(cooling/heating)	high	dB(A)	48	48	50	50	52	52
	Sound power(cooling/heating)	high	dB(A)	48	48	50	50	52	52
FAN	Air flow rate(cooling/heating)	high	m ³ /min	17.0	17.0/17.2	17.0	17.0/17.2	17.5	17.5/17.7
	Speed(cooling/heating)	high	rpm	860	860/860	860	860/860	1060	1060/1060
	Type	Propeller fan							
	Motor output	W		16	16	16	16	27	27
HEAT EXCHANGER	Type			ML- Φ 7Hi-XA		ML- Φ 7Hi-XA		ML- Φ 9.52Hi-XA	
	Rows x stages x fin pitch			2X26X1.32	2X26X1.32	2X26X1.32	2X26X1.32	2X26X1.32	2X26X1.32
REFRIGERANT CIRCUIT	Refrigerant type			R22	R22	R22	R22	R22	R22
	Refrigerant charge	kg		0.43	0.55	0.43	0.55	0.79	1.06
	Maximum allowable distance between indoor and outdoor	m		7	7	7	7	10	10
	Maximum allowable level difference	m		5	5	5	5	5	5
	Refrigerant control	capillary							
COMPRESSOR	Type	Rorary							
	Model			44R233CF		44R233CF		48R313NL	
	Motor output	w		880		880		1230	
	Oil type			SUNISO 4GSD		SUNISO 4GSD		SUNISO 4GSD	
	Oil charge volume	L		0.27		0.27		0.41	
PIPING CONNECTIONS	liquid	mm		Φ 6.35	Φ 6.35	Φ 6.35	Φ 6.35	Φ 6.35	Φ 6.35
	gas	mm		Φ 9.52	Φ 9.52	Φ 9.52	Φ 9.52	Φ 12.7	Φ 12.7
	drain	mm		Φ 16	Φ 16	Φ 16	Φ 16	Φ 16	Φ 16
INSULATION MATERIAL	Heat insulation type			both liquid and gas pipes					

ELECTRICAL SPECIFICATIONS									
For combination indoor units+ outdoor units:				HSU-07LEK03	HSU-07HEK03	HSU-09LEK03	HSU-09HEK03	HSU-12LEK03	HSU-12HEK03
CURRENT	Nominal running current	cooling	A	4.3	4.3	4.5	4.5	5.9	5.9
		heating	A	—	3.6	—	3.9	—	6.1
	Maximum running current	cooling	A	6.2	6.0	6.2	6.0	7.5	7.5
		heating	A	—	5.8	—	5.8	—	7.1
	Starting current	cooling	A	21.5	21.5	21.5	21.5	34	34
		heating	A	—	21.5	—	21.5	—	34

For indoor units only:			HSU-07LEK03	HSU-07HEK03	HSU-09LEK03	HSU-09HEK03	HSU-12LEK03	HSU-12HEK03
POWER SUPPLY			VM	VM	VM	VM	VM	VM
NOMINAL DISTRIBUTION SYSTEM VOLTAGE	Phase		1PH	1PH	1PH	1PH	1PH	1PH
	Frequency	HZ	50	50	50	50	50	50
	Voltage	V	220	220	220	220	220	220

NOTES

- Nominal cooling capacities are based on: indoor temperature 27°CDB/19°CWB * outdoor temperature 35°CDB * refrigerant piping length: 5m * level difference: 0m.
- Nominal heating capacities are based on: indoor temperature 20°CDB * outdoor temperature 7°CDB/6°CWB * refrigerant piping length 5m (horizontal) * level difference 0m.
- Capacities are net, including a deduction for cooling (an addition for heating) for indoor fan motor heat.
- Units should be selected on nominal capacity. Maximum capacity is limited to peak periods.
- The sound pressure level is measured in an anechoic room at 1m distance from the unit. It is a relative value, depending on the distance and acoustic environment. For measuring conditions: please refer to item 8 of this chapter.
- The sound power level is an absolute value indicating the "power" which a sound source generates.
- Energy label: scale from A (most efficient) to G (less efficient).
- The energy label Directive 2002/31/EC will enter into force once the relevant measurement standard will be published in the European official Standard.
- Annual energy consumption: based on average use of 500 running hours per year at full load (= nominal conditions)

3 Remote controller lists

Mode	HSU-07LEK03	HSU-07HEK03	HSU-09LEK03	HSU-09HEK03	HSU-12LEK03	HSU-12HEK03
YR-M07	N	N	N	N	N	N
YR-H75	N	N	N	N	N	N
YR-M05	N	N	N	N	N	N
YR-H03	N	N	N	N	N	N
YL-W04	Y	N	Y	N	Y	N
YR-W04	N	Y	N	Y	N	Y

4 Sensors lists

INDOOR UNIT		
type	Description	Qty
Room sensor	It's used for detecting room temperature	1
Pipe sensor	It's used for detecting temperature of evaporator	1

5 Dimensional drawings

Indoor unit

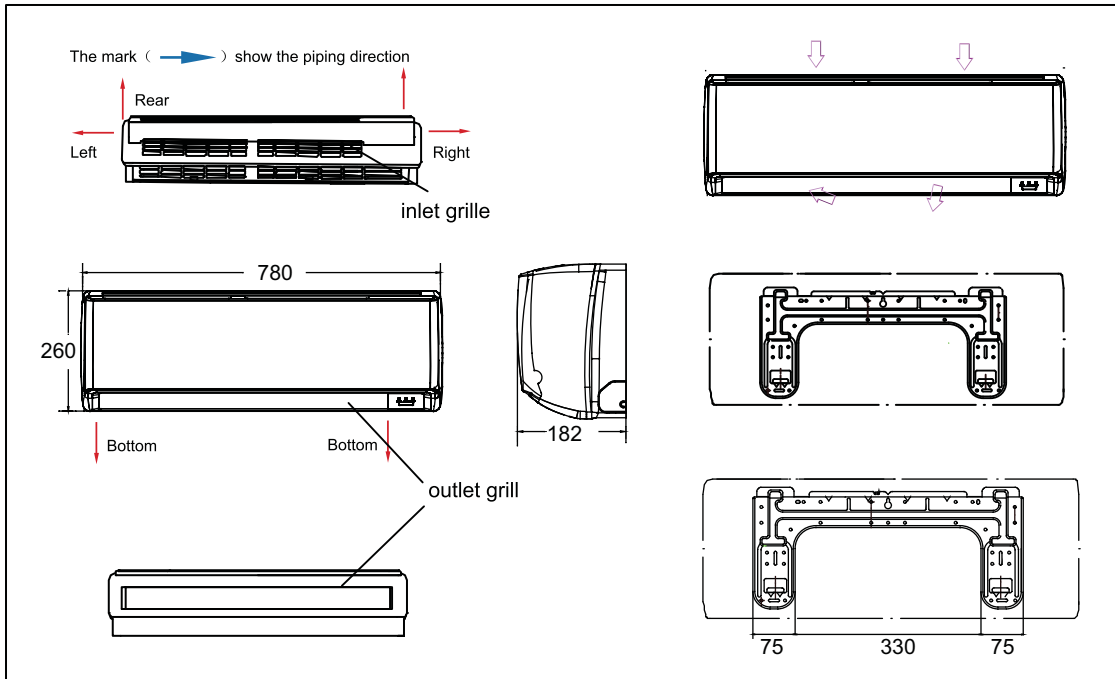

Outdoor unit

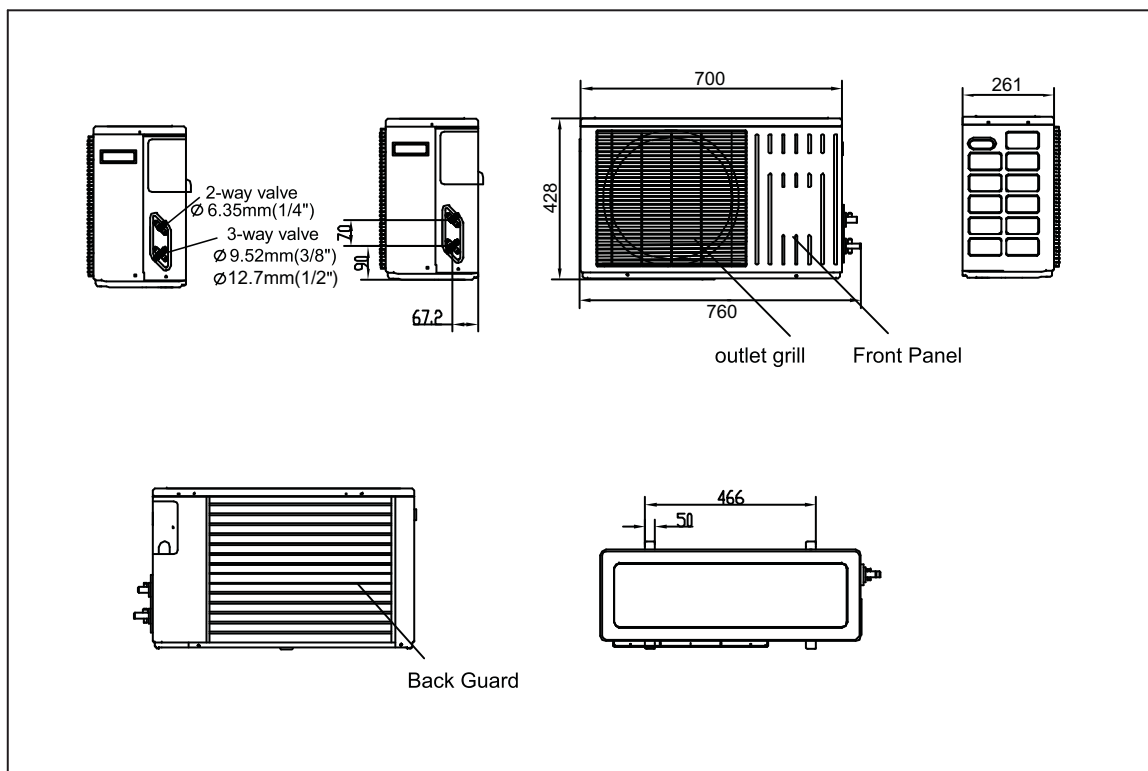

6 Operation range

The name of parts

Cooling

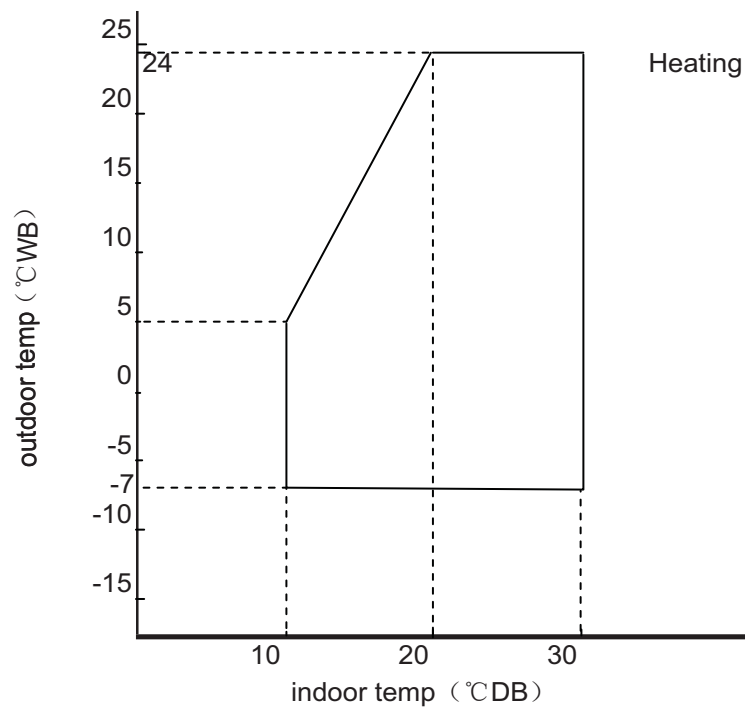
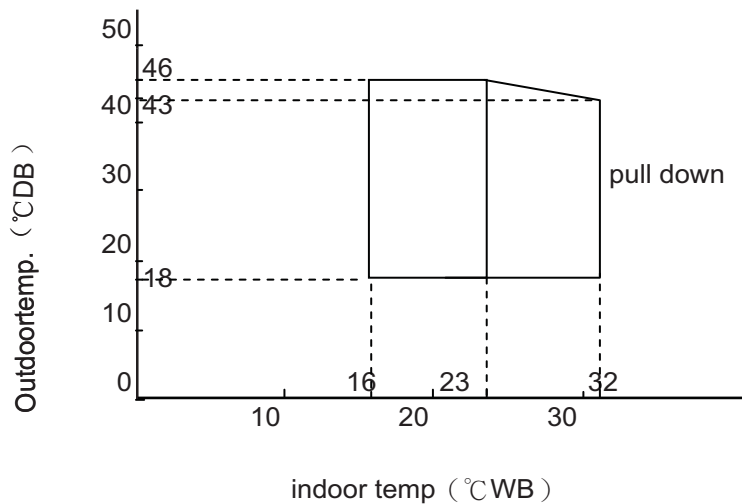

Notes:

The graphs are based on the following condition:

Equivalent piping length	7.5m
Level difference	0m
Air flow rate	high

7 Piping diagrams

Cooling mode

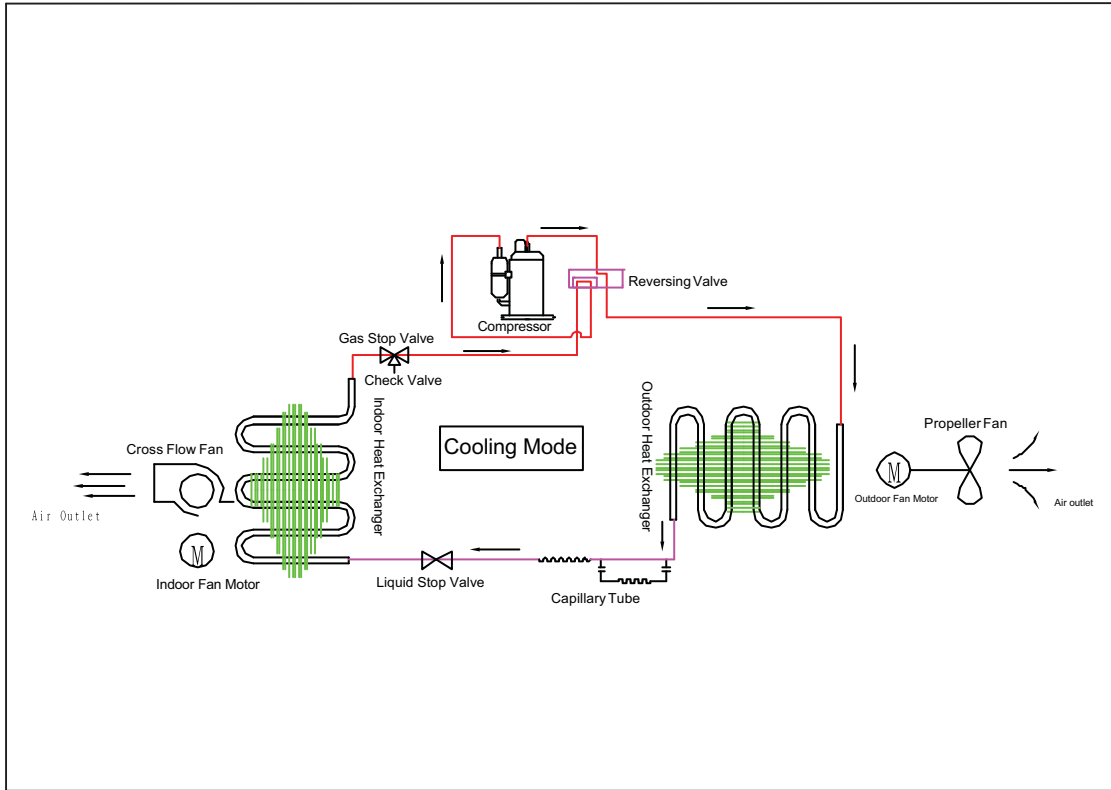

Heating mode

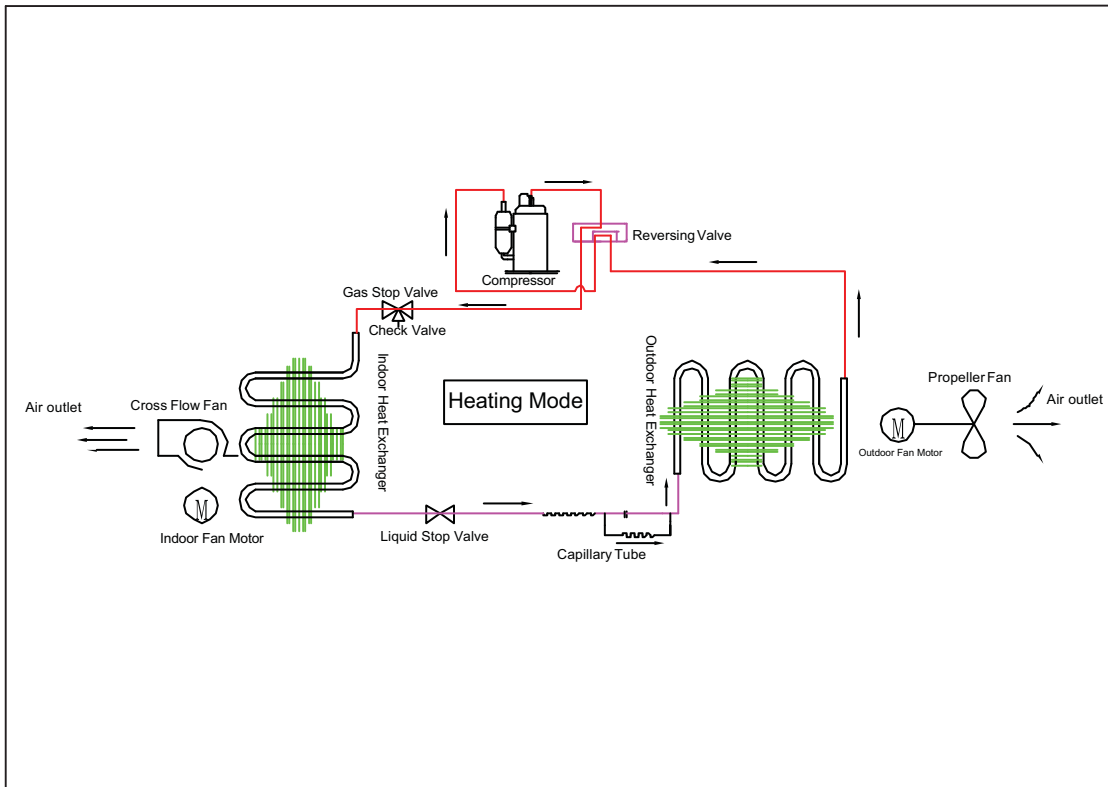

8 Wiring Diagrams

8.1 Indoor unit

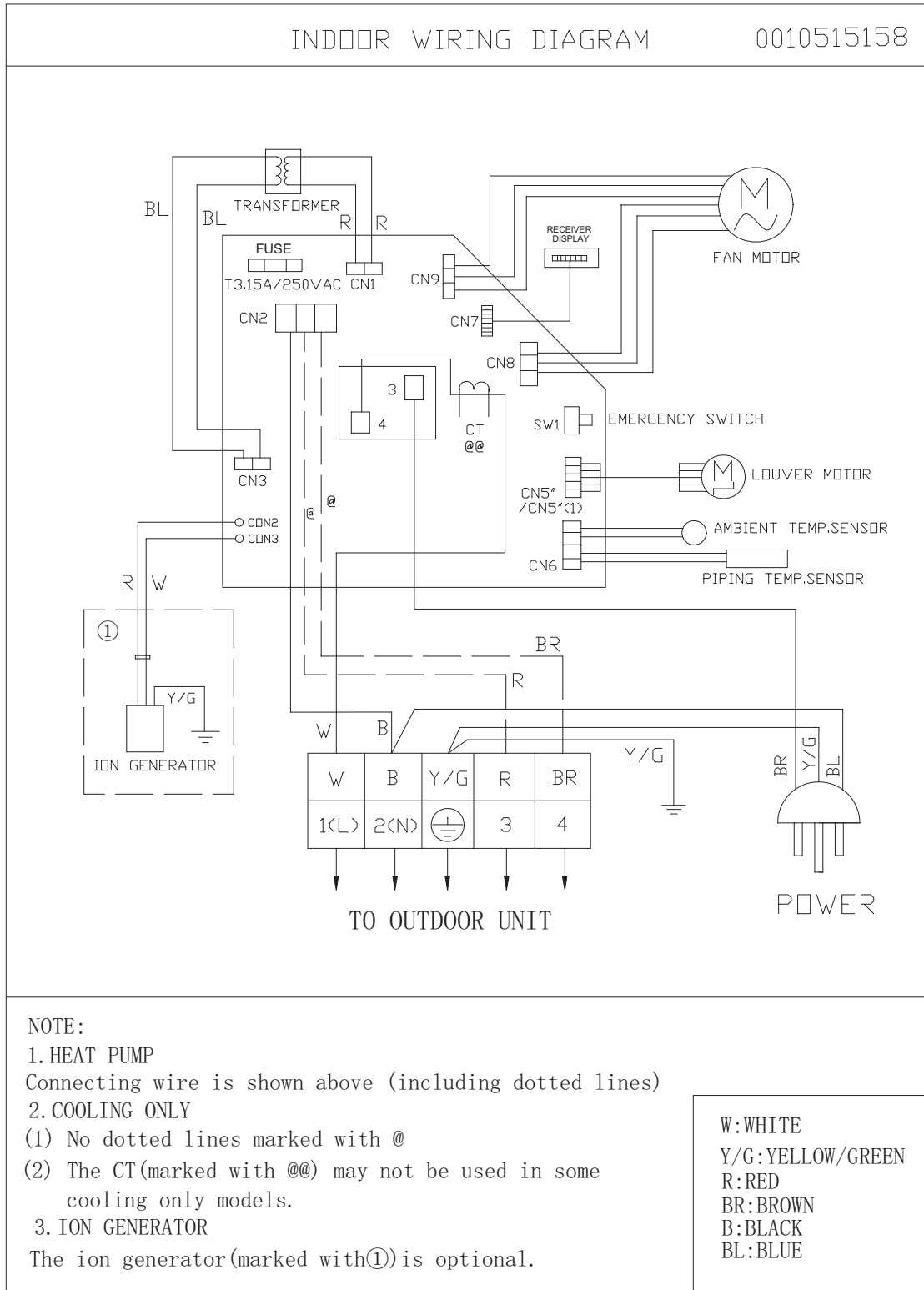

8.2 Outdoor unit

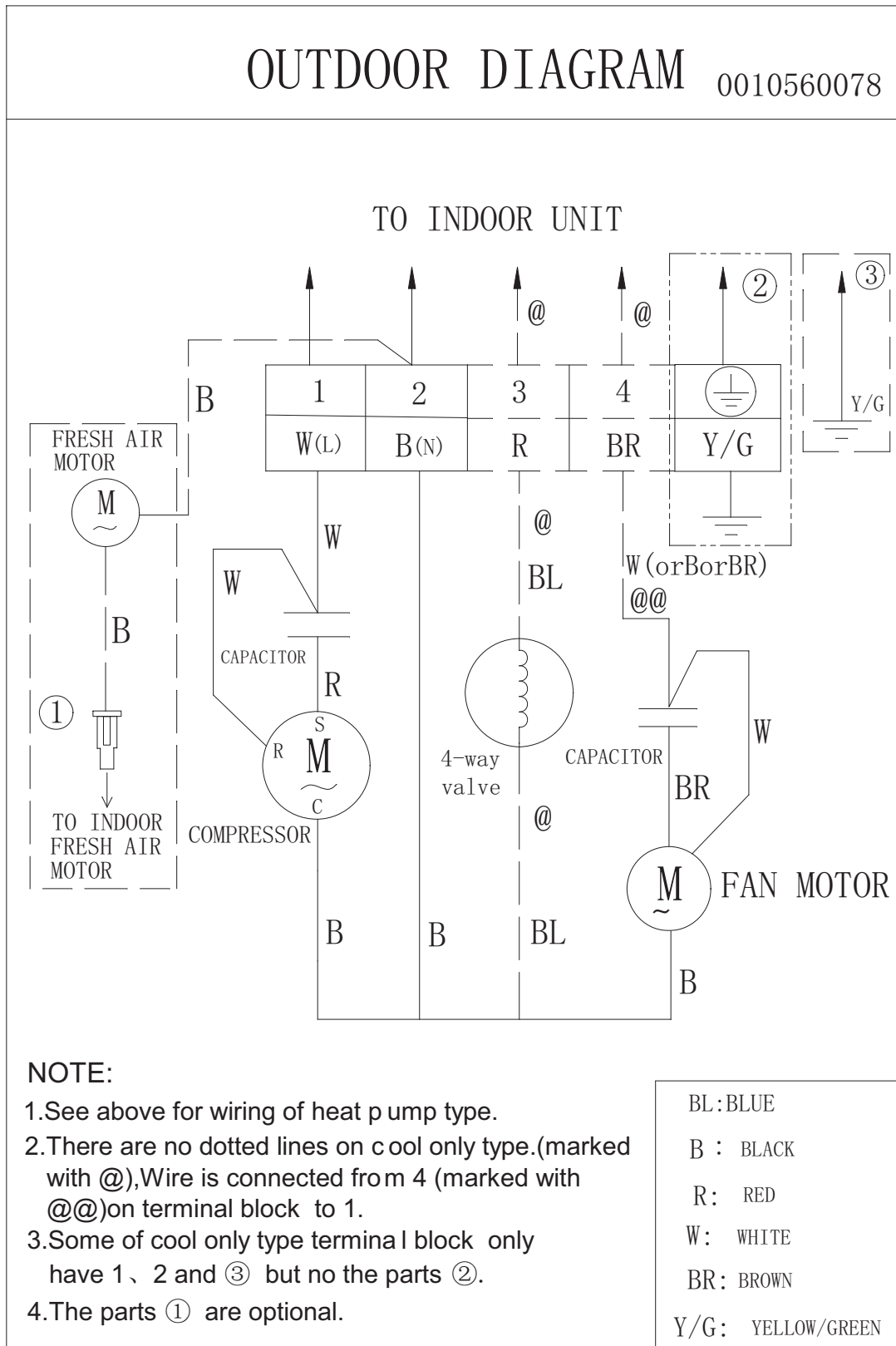

9 Capacity tables and curves diagrams

9.1 Cooling Capacity-temperature Curves

HSU-07L HEK03 performance curves								
cooling value-temperature talbe								
indoor temp	outdoor temp.(humidity 46%)							
DB/WB	18℃	20℃	25℃	32℃	35℃	40℃	43℃	46℃
18/12℃	1566	1577	1587	1366	1376	1419	1269	1053
18/14℃	2049	2060	2127	1875	1838	1708	1596	1410
20/15℃	2531	2544	2557	2462	2300	2139	2003	1767
22/16℃	2477	2493	2510	2442	2267	2061	1922	1757
25/18℃	2424	2443	2462	2421	2234	2048	1925	1729
27/19℃	2685	2595	2645	2482	2380	2229	2106	1882
30/22℃	2962	2814	3002	2708	2578	2448	2276	2129
32/23℃	3062	2798	3008	2679	2622	2513	2385	2157
32/24℃	3141	2872	3086	2751	2693	2581	2450	2220

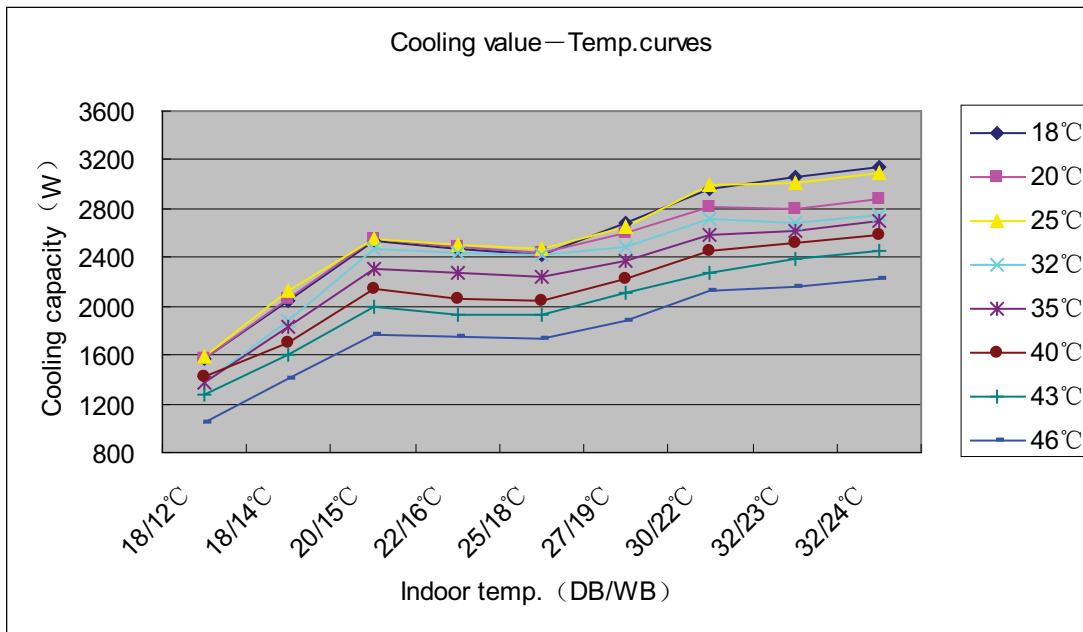

HSU-09L HEK03 performance curves								
cooling value-temperature talbe								
indoor temp	outdoor temp.(humidity 46%)							
DB/WB	18°C	20°C	25°C	32°C	35°C	40°C	43°C	46°C
18/12°C	1686	1697	1707	1486	1496	1539	1389	1173
18/14°C	2169	2180	2247	1995	1958	1828	1716	1530
20/15°C	2651	2664	2677	2582	2420	2259	2123	1887
22/16°C	2597	2613	2630	2562	2387	2181	2042	1877
25/18°C	2544	2563	2582	2541	2354	2168	2045	1849
27/19°C	2805	2715	2765	2602	2500	2349	2226	2002
30/22°C	3082	2934	3122	2828	2698	2568	2396	2249
32/23°C	3182	2918	3128	2799	2742	2633	2505	2277
32/24°C	3261	2992	3206	2871	2813	2701	2570	2340

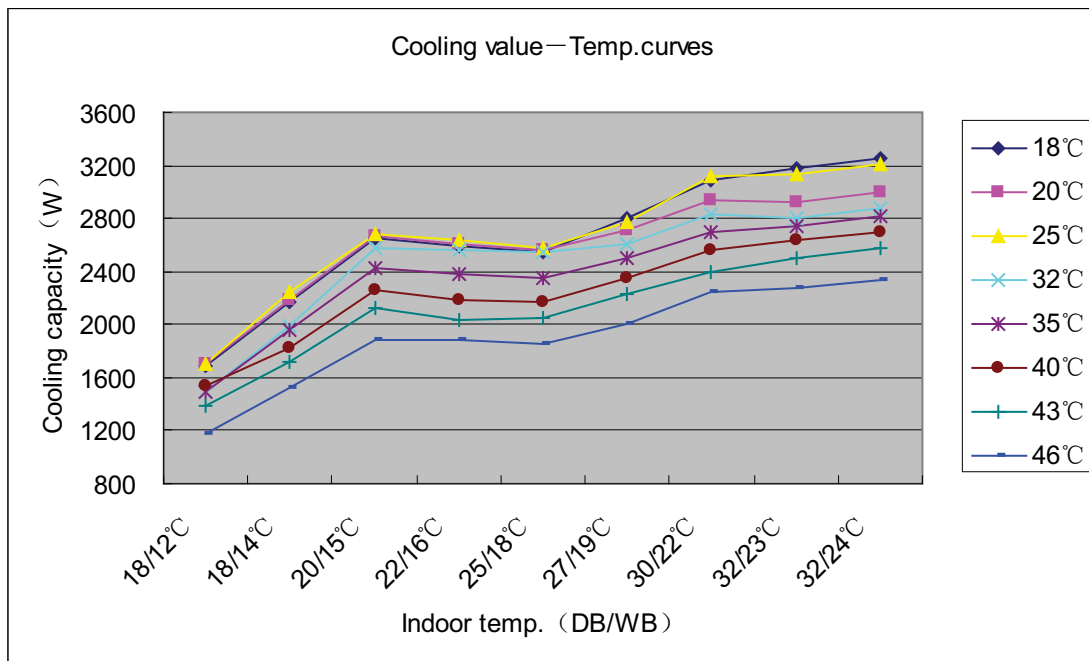

HSU-12L HEK03 performance curves								
cooling value-temperature talbe								
indoor temp	outdoor temp.(humidity 46%)							
DB/WB	18°C	20°C	25°C	32°C	35°C	40°C	43°C	46°C
18/12°C	2686	2697	2707	2486	2496	2539	2389	2173
18/14°C	3169	3180	3247	2995	2958	2828	2716	2530
20/15°C	3651	3664	3677	3582	3420	3259	3123	2887
22/16°C	3597	3613	3630	3562	3387	3181	3042	2877
25/18°C	3544	3563	3582	3541	3354	3168	3045	2849
27/19°C	3805	3715	3765	3602	3500	3349	3226	3002
30/22°C	4082	3934	4122	3828	3698	3568	3396	3249
32/23°C	4182	3918	4128	3799	3742	3633	3505	3277
32/24°C	4261	3992	4206	3871	3813	3701	3570	3340

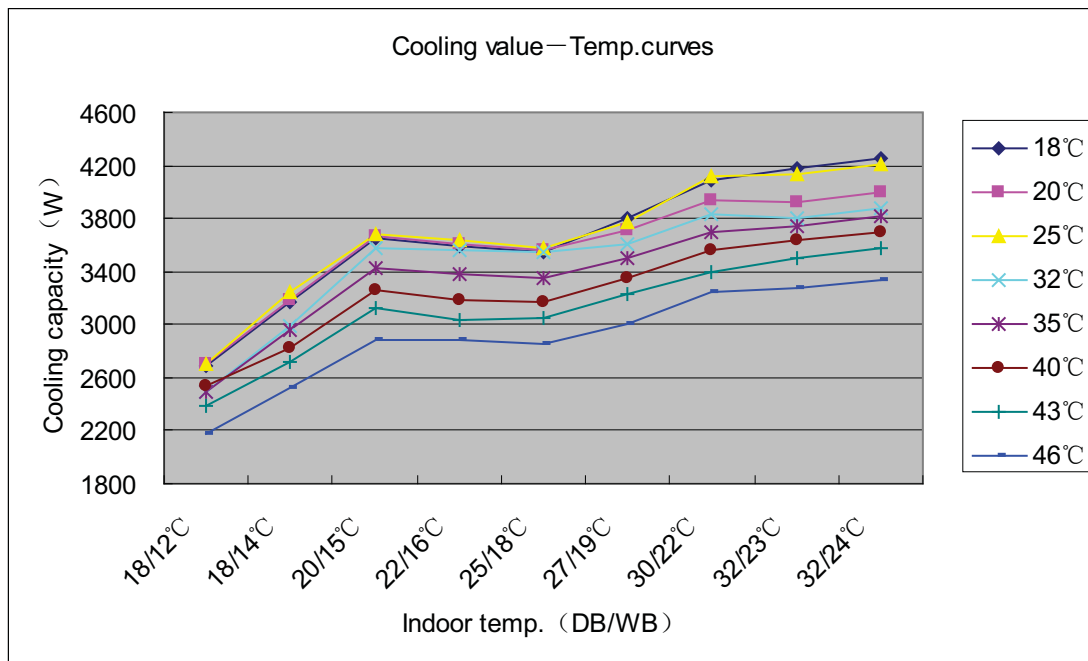

9.2 Heating Capacity-temperature Curves

HSU-07HEK03 performance curves			
heating capacity and indoor/outdoor temp.curves			
outdoor temp.	indoor temp.(humidity 46%)		
DB/WB	15°C	20°C	25°C
-15°C	495	422	325
-5°C	1334	1248	1125
5°C	1736	1644	1519
7/6°C	2249	2650	1778
15°C	2750	2800	2550
20°C	3050	2950	2850
25°C	3550	3300	3050

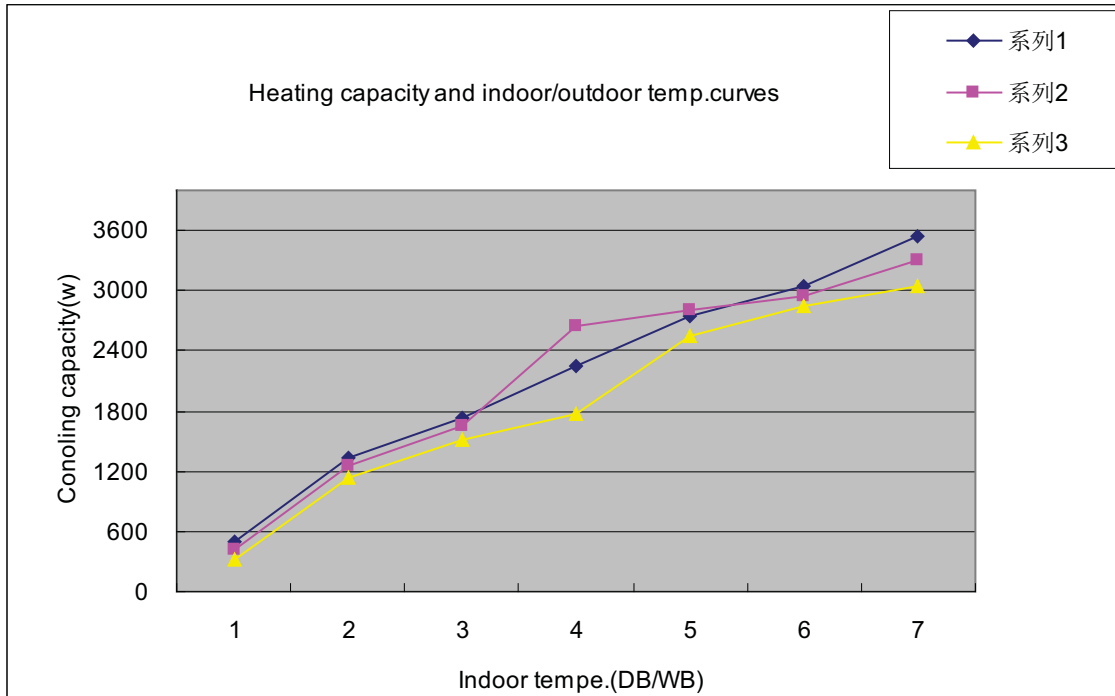

HSU-09HEK03 performance curves			
heating capacity and indoor/outdoor temp.curves			
outdoor temp.	indoor temp.(humidity 46%)		
DB/WB	15°C	20°C	25°C
-15°C	595	522	425
-5°C	1434	1348	1225
5°C	1836	1744	1619
7/6°C	2349	2750	1878
15°C	2850	2900	2650
20°C	3150	3050	2950
25°C	3650	3400	3150

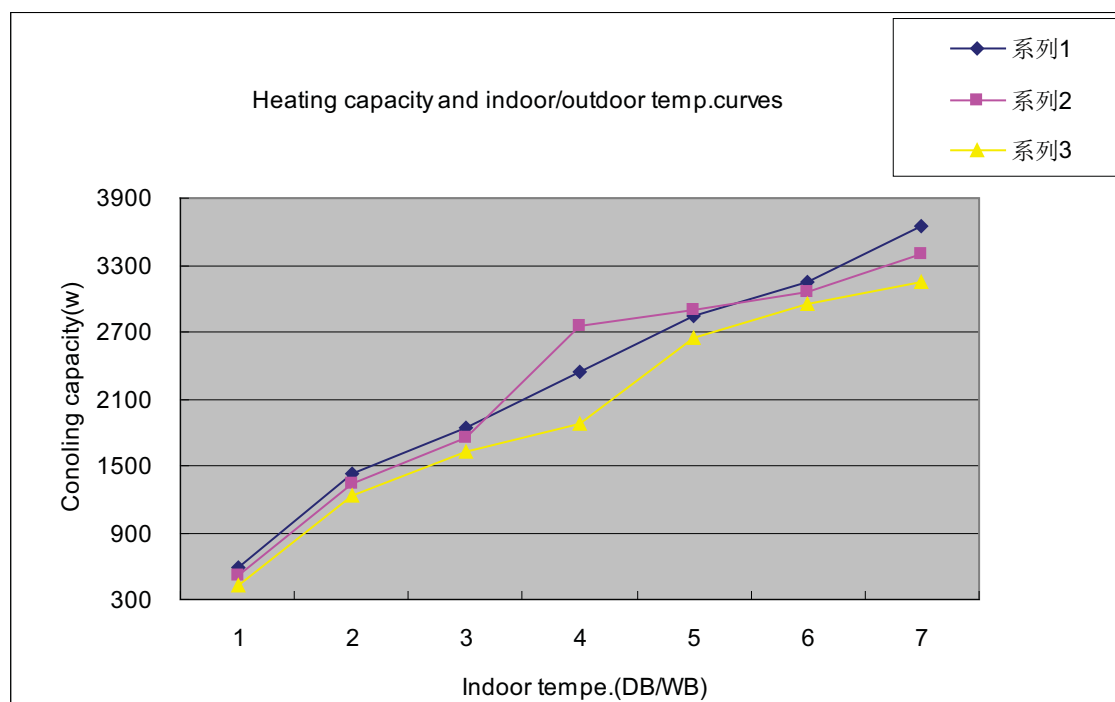

HSU-12HEK03 performance curves			
heating capacity and indoor/outdoor temp.curves			
outdoor temp.	indoor temp.(humidity 46%)		
DB/WB	15°C	20°C	25°C
-15°C	1645	1572	1475
-5°C	2484	2398	2275
5°C	2886	2794	2669
7/6°C	3399	3800	2928
15°C	3900	3950	3700
20°C	4200	4100	4000
25°C	4700	4450	4200

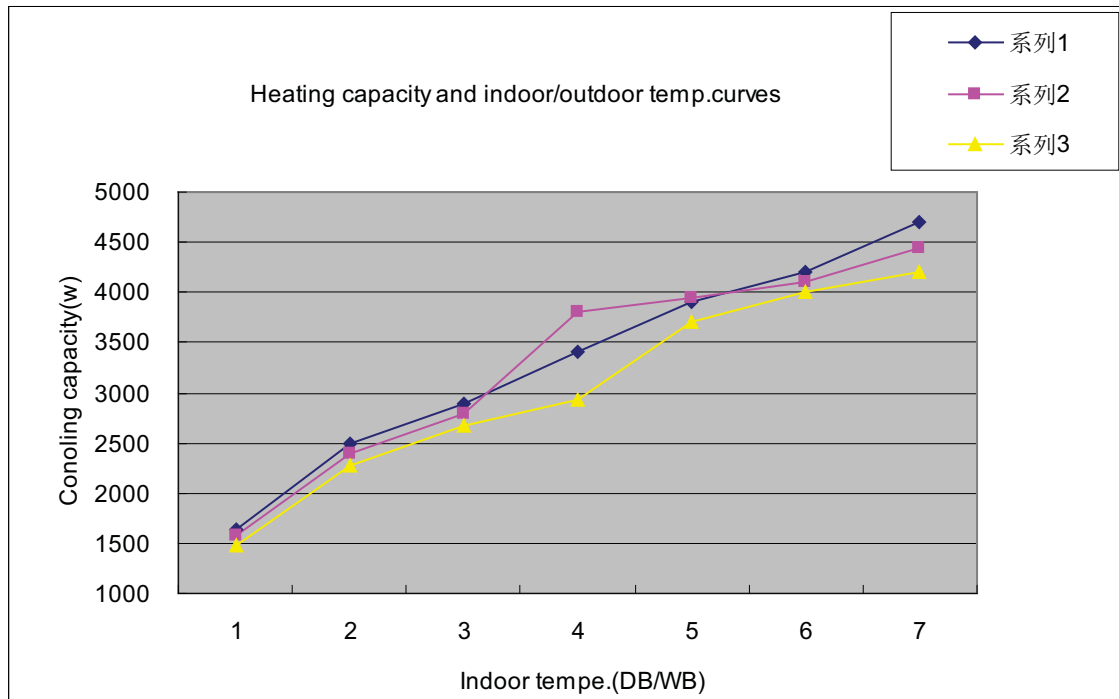

9.3 Cooling Power Consumption Value-temperature Curves

HSU-07L HEK03 performance curves								
power consumption value-teme.talbe								
indoor temp.	outdoor temp.(humidity 46%)							
DB/WB	18 °C	20 °C	25 °C	32 °C	35 °C	40 °C	43 °C	46 °C
18/12 °C	488	496	511	608	735	955	1011	1066
18/14 °C	562	570	587	694	834	1076	1137	1198
20/15 °C	663	642	630	831	862	997	1074	1152
22/16 °C	666	644	631	847	870	998	1077	1157
25/18 °C	668	646	632	862	878	999	1080	1161
27/19 °C	686	663	650	885	900	1024	1107	1190
30/22 °C	705	682	668	907	923	1049	1134	1219
32/23 °C	711	674	647	866	902	1047	1144	1241
32/24 °C	730	684	656	877	914	1060	1158	1256

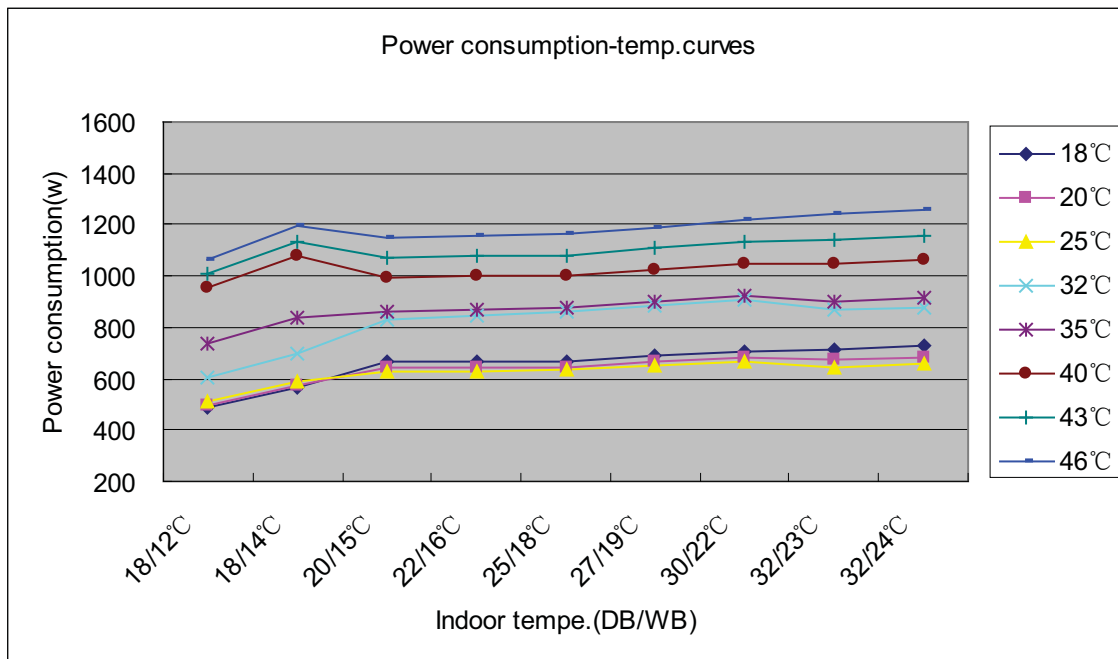

HSU-09L HEK03 performance curves								
power consumption value-temp.talbe								
indoor temp.	outdoor temp.(humidity 46%)							
DB/WB	18°C	20°C	25°C	32°C	35°C	40°C	43°C	46°C
18/12°C	528	536	551	648	775	995	1051	1106
18/14°C	602	610	627	734	874	1116	1177	1238
20/15°C	703	682	670	871	902	1037	1114	1192
22/16°C	706	684	671	887	910	1038	1117	1197
25/18°C	708	686	672	902	918	1039	1120	1201
27/19°C	726	703	690	925	940	1064	1147	1230
30/22°C	745	722	708	947	963	1089	1174	1259
32/23°C	751	714	687	906	942	1087	1184	1281
32/24°C	770	724	696	917	954	1100	1198	1296

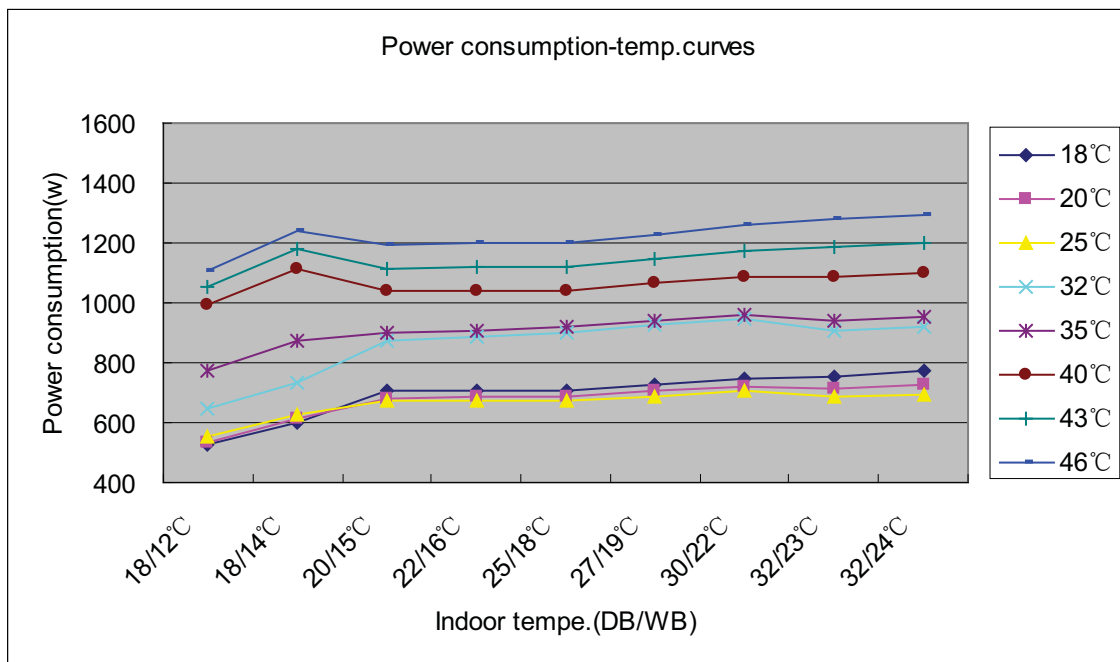

HSU-12L HEK03 performance curves								
power consumption value-teme.talbe								
indoor temp.	outdoor temp.(humidity 46%)							
DB/WB	18°C	20°C	25°C	32°C	35°C	40°C	43°C	46°C
18/12°C	838	846	861	958	1085	1305	1361	1416
18/14°C	912	920	937	1044	1184	1426	1487	1548
20/15°C	1013	992	980	1181	1212	1347	1424	1502
22/16°C	1016	994	981	1197	1220	1348	1427	1507
25/18°C	1018	996	982	1212	1228	1349	1430	1511
27/19°C	1036	1013	1000	1235	1250	1374	1457	1540
30/22°C	1055	1032	1018	1257	1273	1399	1484	1569
32/23°C	1061	1024	997	1216	1252	1397	1494	1591
32/24°C	1080	1034	1006	1227	1264	1410	1508	1606

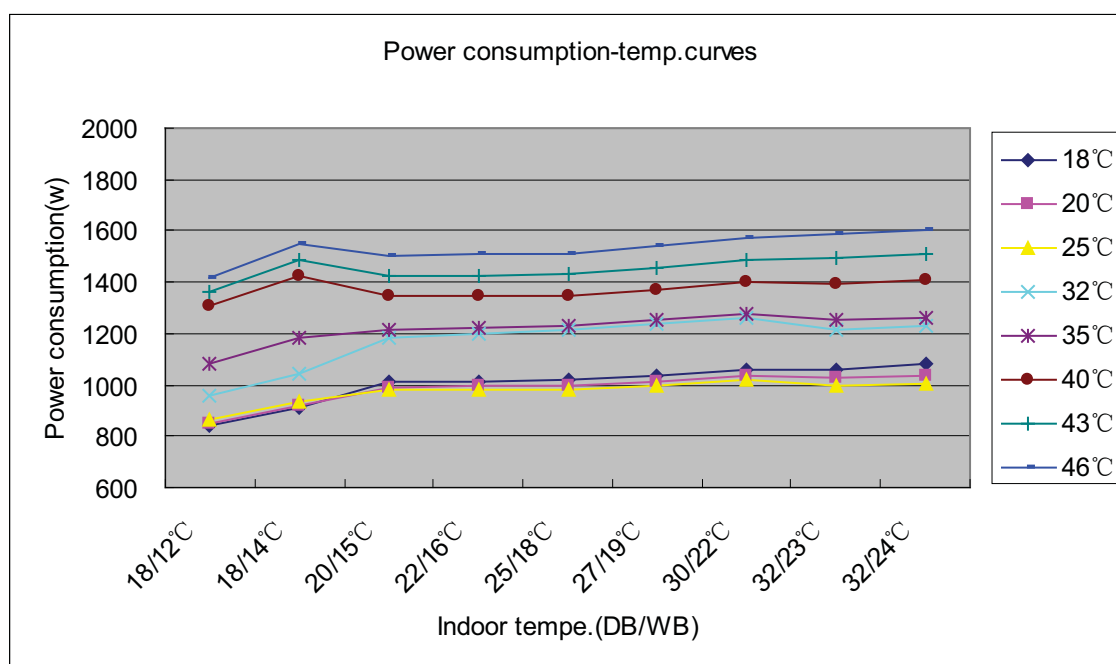

9.4 Heating Power Consumption Value-temperature Curves

HSU-07HEK03 performance curves			
power consumption value-temp.talbe			
outdoor temp.	indoor temp.(humidity 46%)		
DB/WB	15°C	20°C	25°C
-15°C	506	549	586
-5°C	581	660	697
5°C	592	659	716
7/6°C	720	750	768
15°C	802	836	856
20°C	610	679	757
25°C	519	606	673

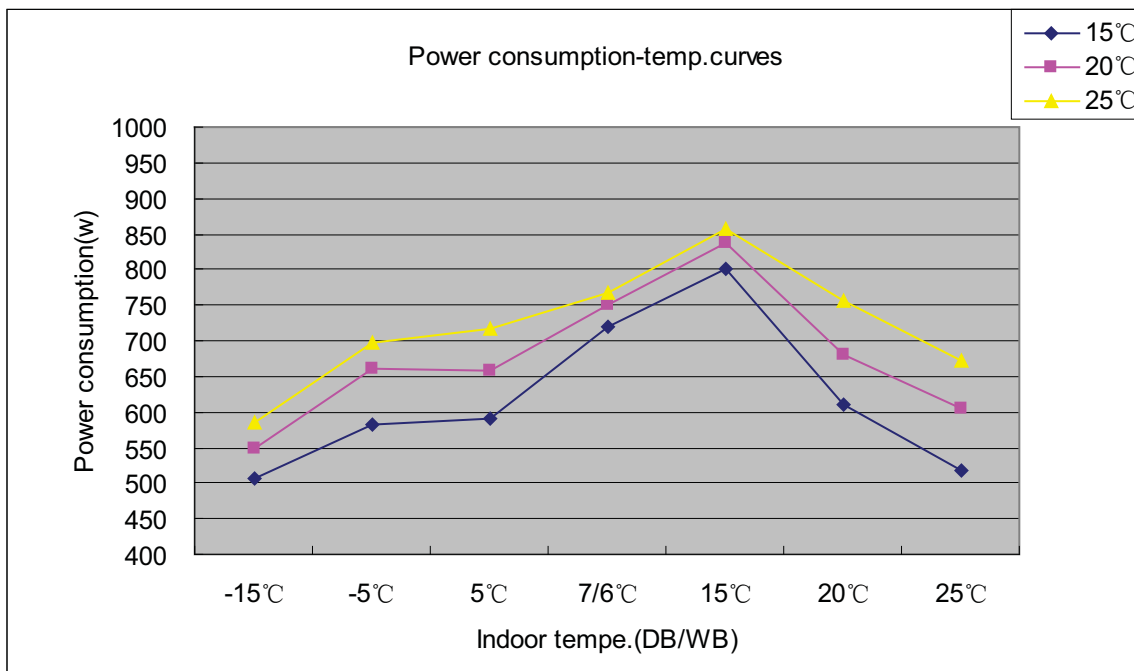

HSU-09HEK03 performance curves			
power consumption value-temp.talbe			
outdoor temp.	indoor temp.(humidity 46%)		
DB/WB	15°C	20°C	25°C
-15°C	606	649	686
-5°C	681	760	797
5°C	692	759	816
7/6°C	820	850	868
15°C	902	936	956
20°C	710	779	857
25°C	619	706	773

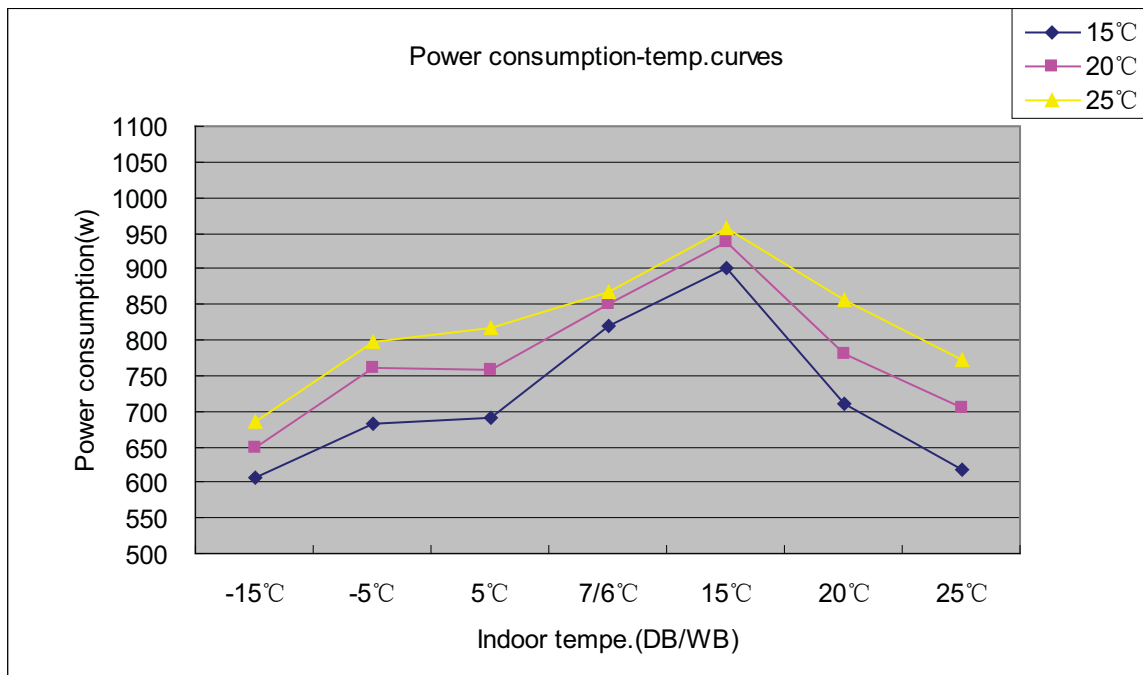

HSU-12HEK03 performance curves			
power consumption value-temp.talbe			
outdoor temp.	indoor temp.(humidity 46%)		
DB/WB	15°C	20°C	25°C
-15°C	1036	1079	1116
-5°C	1111	1190	1227
5°C	1122	1189	1246
7/6°C	1250	1280	1298
15°C	1332	1366	1386
20°C	1140	1209	1287
25°C	1049	1136	1203

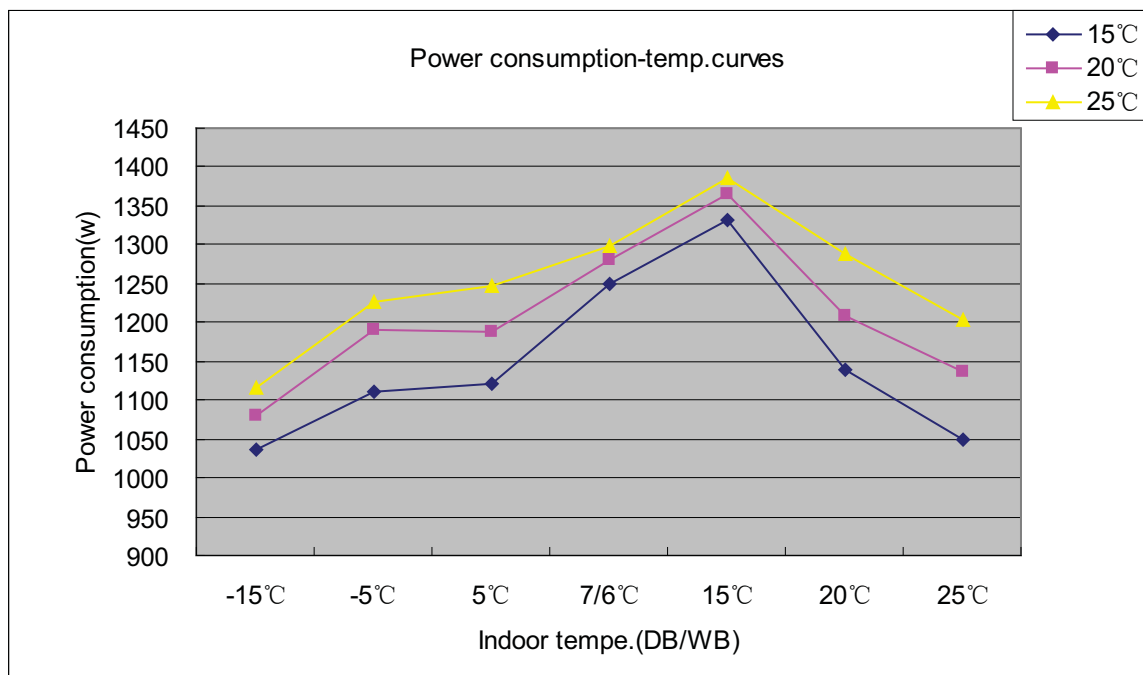

9.5 Cooling Discharge Pressure Curves

HSU-07 09L HEK03 performance curves			
Cooling discharge pressure .table			
outdoor temp. (humidity 46%)	indoor temp.		
DB/WB	16°C	19°C	22°C
15°C	2259	2392	2475
25°C	2410	2542	2653
30°C	2714	2846	2947
35°C	3018	3129	3271
40°C	3301	3392	3554
45°C	3578	3696	3795

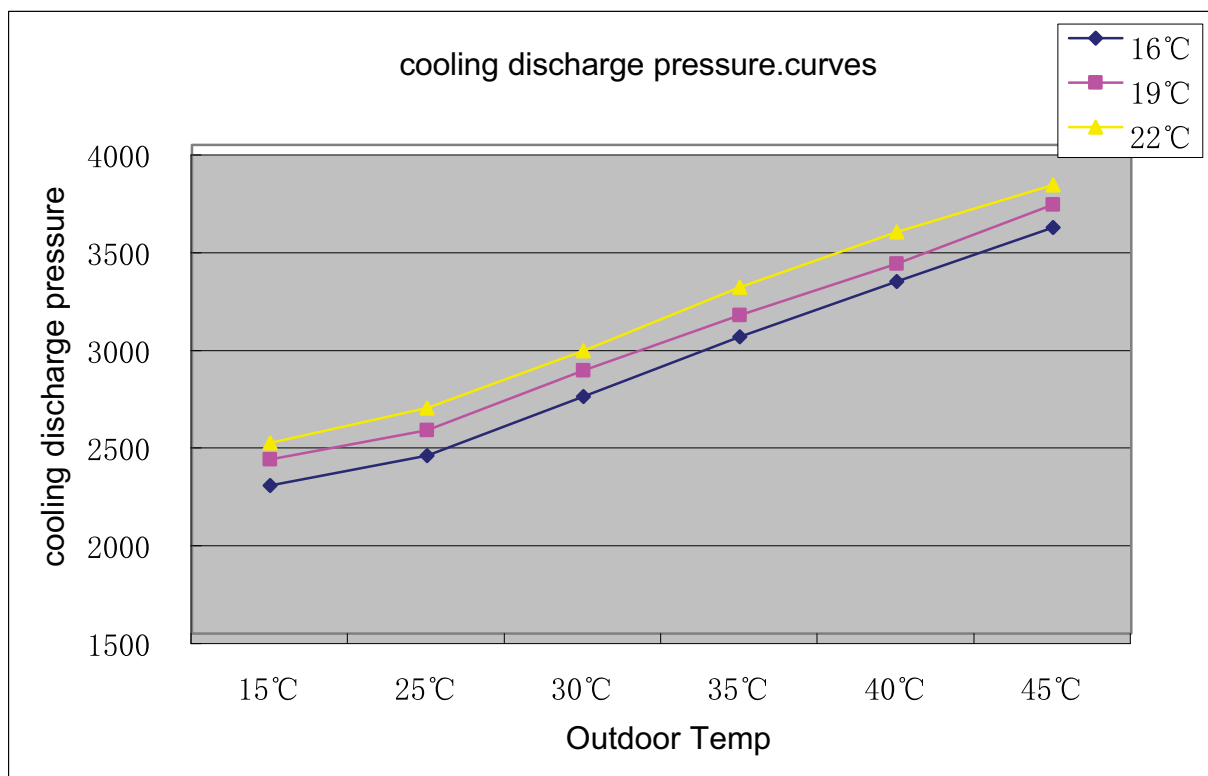

HSU-12L HEK03 performance curves			
Cooling discharge pressure .table			
outdoor temp. (humidity 46%)	indoor temp.		
DB/WB	16°C	19°C	22°C
15°C	2131	2268	2352
25°C	2286	2421	2535
30°C	2597	2732	2835
35°C	2908	3021	3166
40°C	3197	3291	3456
45°C	3481	3601	3703

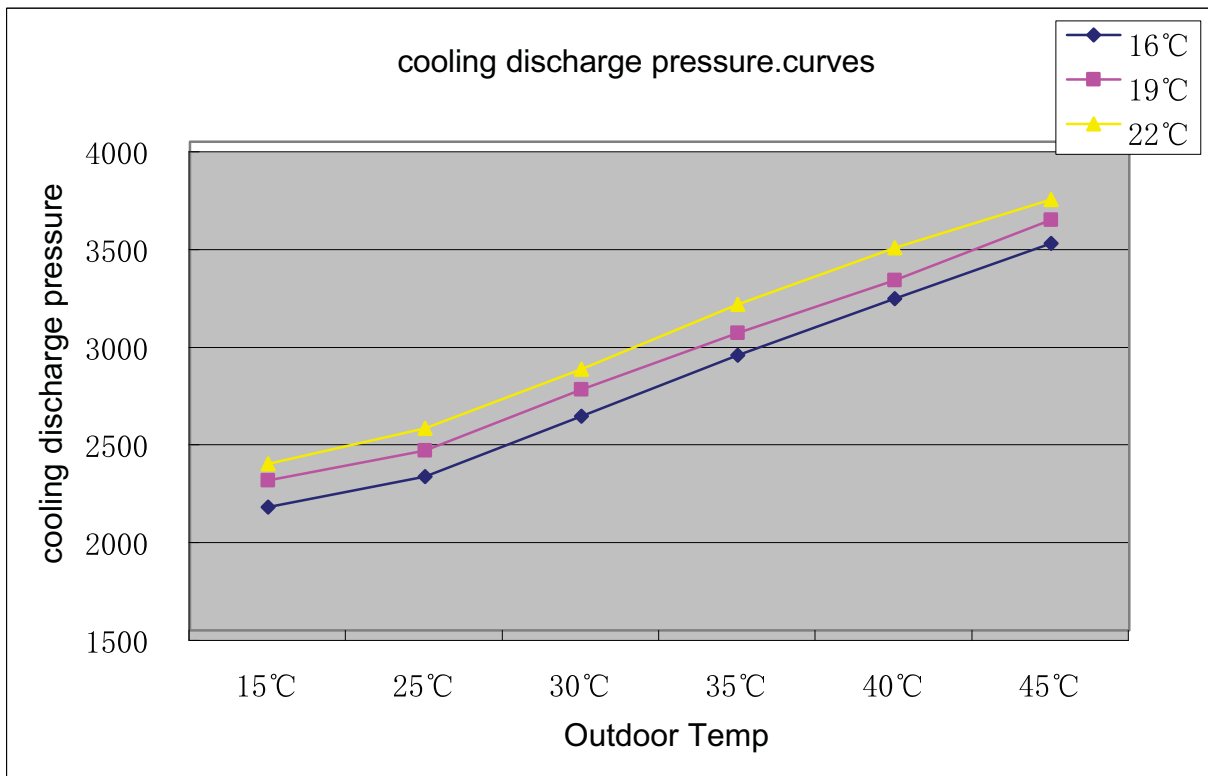

9.6 Heating Discharge Pressure Curves

HSU-09HEK03 performance curves			
Heating discharge pressure.table			
outdoor temp. (humidity 46%)	indoor temp.		
DB/WB	15°C	20°C	25°C
-10°C	1909	2111	2304
-5°C	2160	2304	2496
0°C	2364	2537	2759
5°C	2638	2830	3013
10°C	2891	3110	3286
15°C	3134	3367	3616
20°C	3377	3621	3813

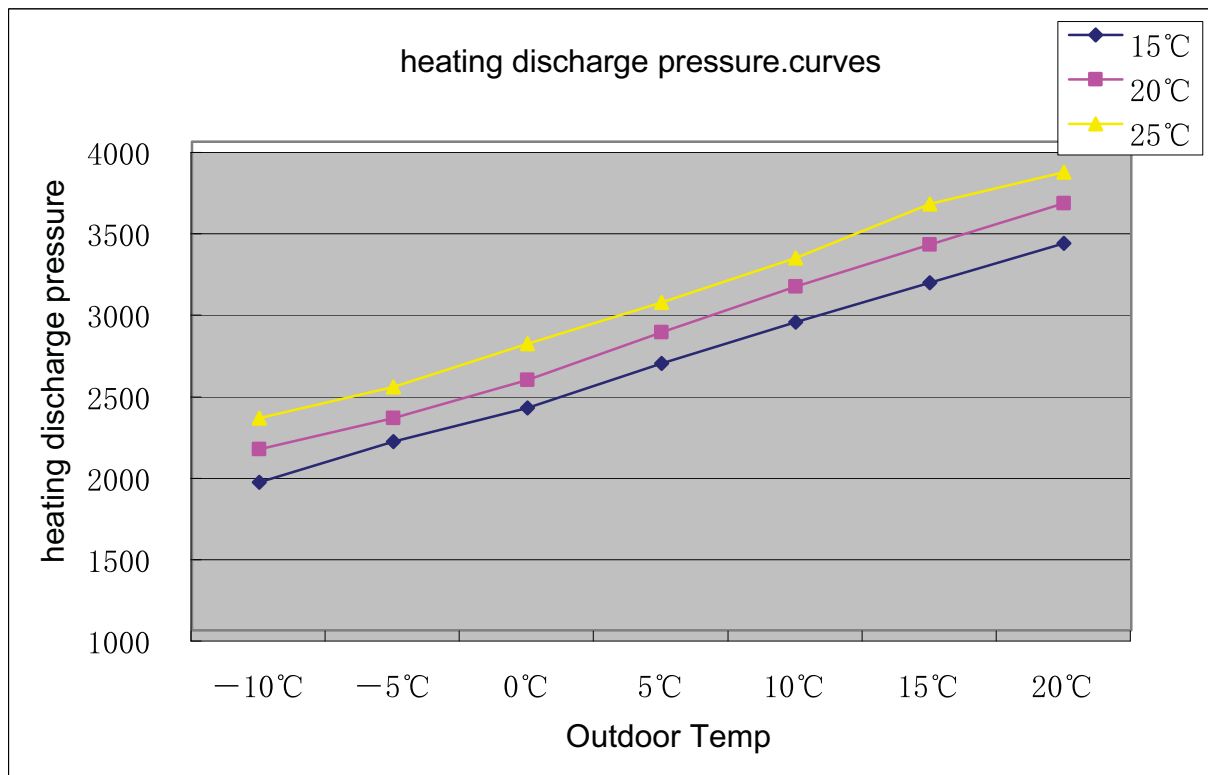

HSU-12HEK03 performance curves			
Heating discharge pressure.table			
outdoor temp. (humidity 46%)	indoor temp.		
	15°C	20°C	25°C
DB/WB			
−10°C	1677	1883	2078
−5°C	1932	2078	2273
0°C	2139	2314	2539
5°C	2416	2611	2796
10°C	2673	2895	3073
15°C	2919	3155	3407
20°C	3165	3412	3607

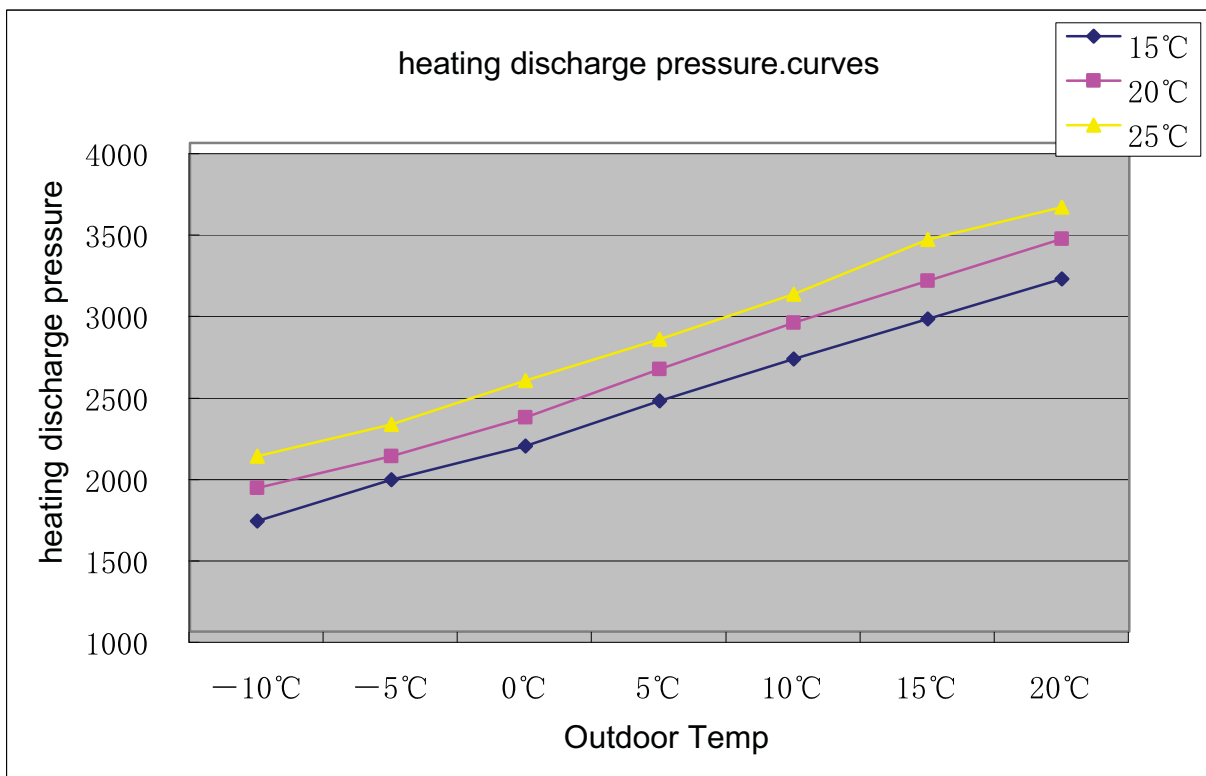

9.7 Cooling Suction Pressure Curves

HSU-07 09L HEK03 performance curves			
Cooling suction pressure.			
outdoor temp. (humidity 46%)	indoor temp.		
DB/WB	16°C	19°C	22°C
15°C	636	679	712
25°C	666	712	742
30°C	693	745	775
35°C	731	783	816
40°C	775	818	859
45°C	813	861	909

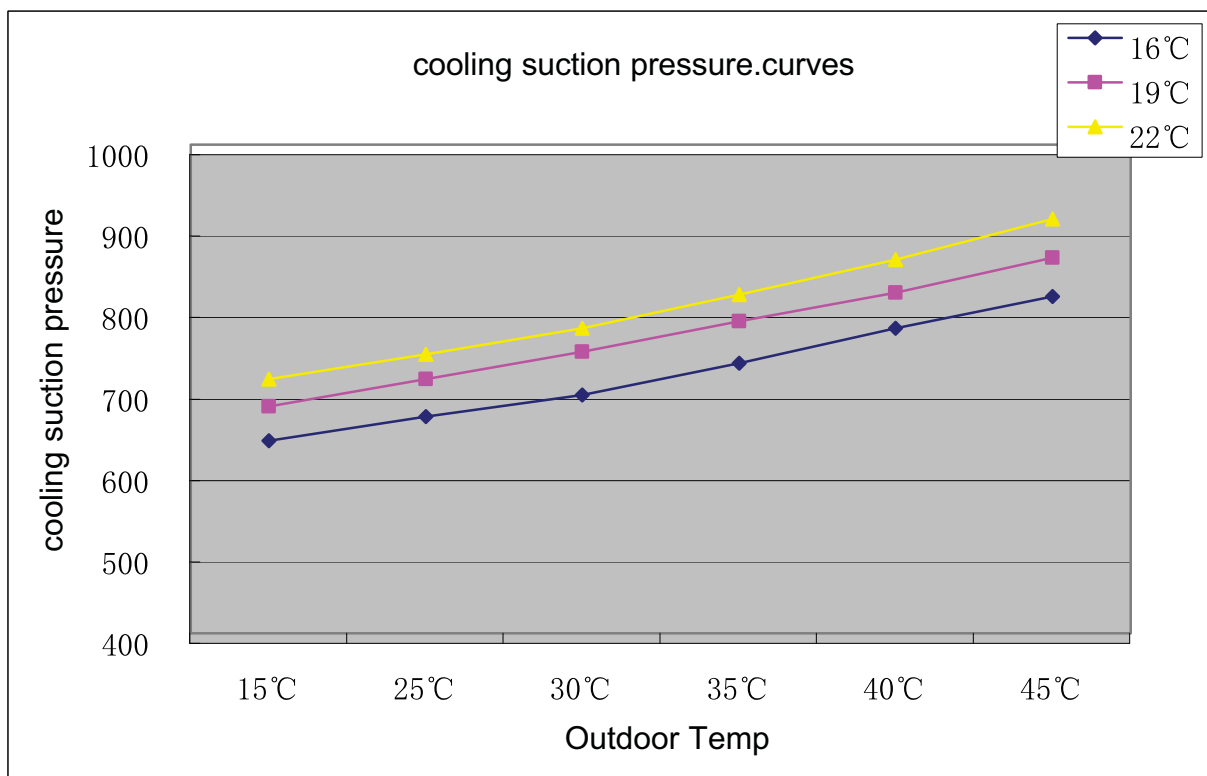

HSU-12L HEK03 performance curves			
Cooling suction pressure.			
outdoor temp. (humidity 46%)	indoor temp.		
DB/WB	16°C	19°C	22°C
15°C	605	649	683
25°C	637	683	714
30°C	663	717	747
35°C	703	756	789
40°C	747	792	833
45°C	787	835	884

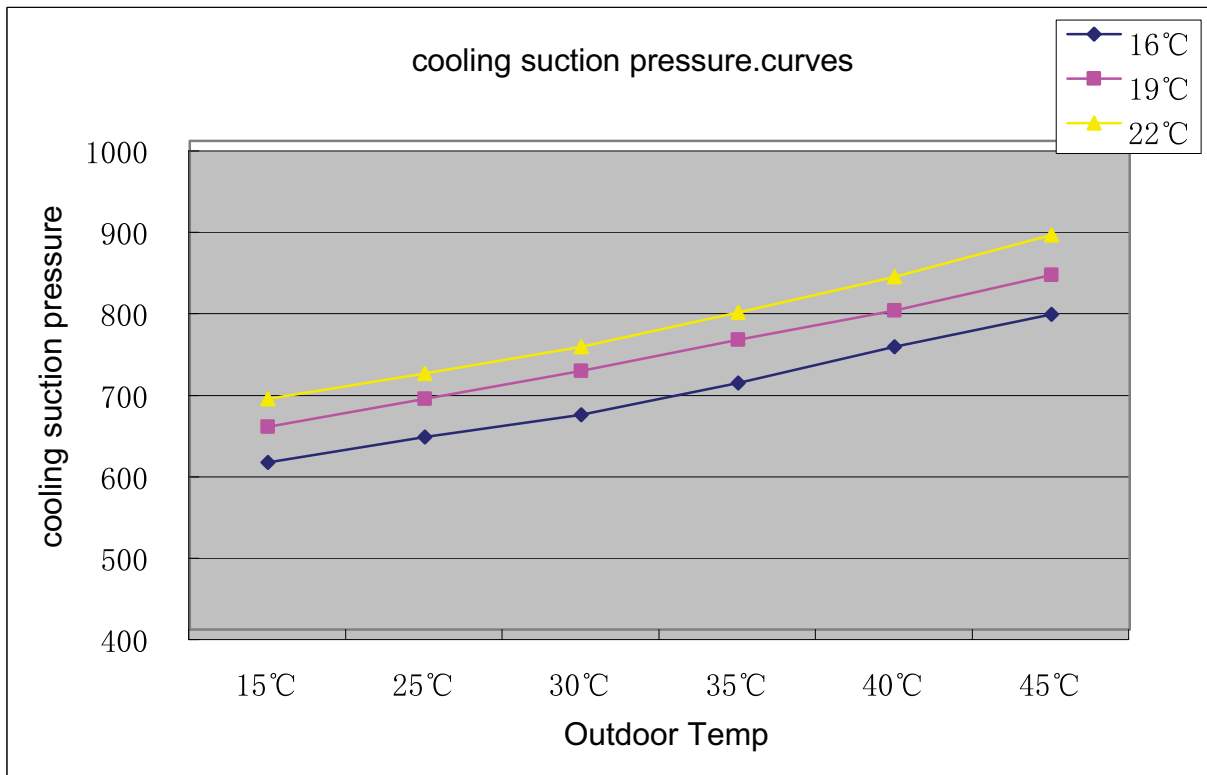

9.8 Heating Suction Pressure Curves

HSU-07 09HEK03 performance curves			
Heating suction pressure.table			
outdoor temp. (humidity 46%)	indoor temp.		
DB/WB	15°C	20°C	25°C
-10°C	273	286	313
-5°C	332	367	411
0°C	427	473	487
5°C	520	545	588
10°C	612	653	689
15°C	691	729	759
20°C	755	793	828

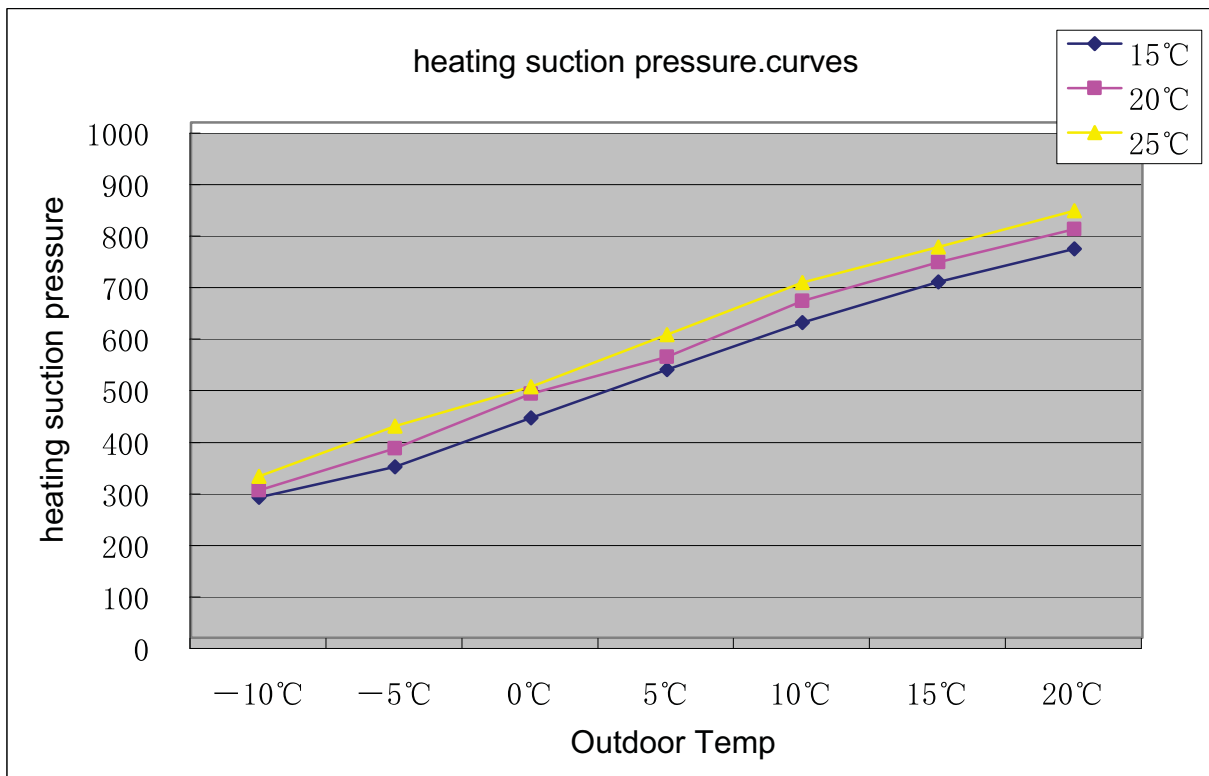

HSU-12HEK03 performance curves			
Heating suction pressure.table			
outdoor temp. (humidity 46%)	indoor temp.		
DB/WB	15°C	20°C	25°C
-10°C	226	239	267
-5°C	285	321	366
0°C	382	429	443
5°C	476	502	545
10°C	570	611	648
15°C	649	688	718
20°C	714	753	789

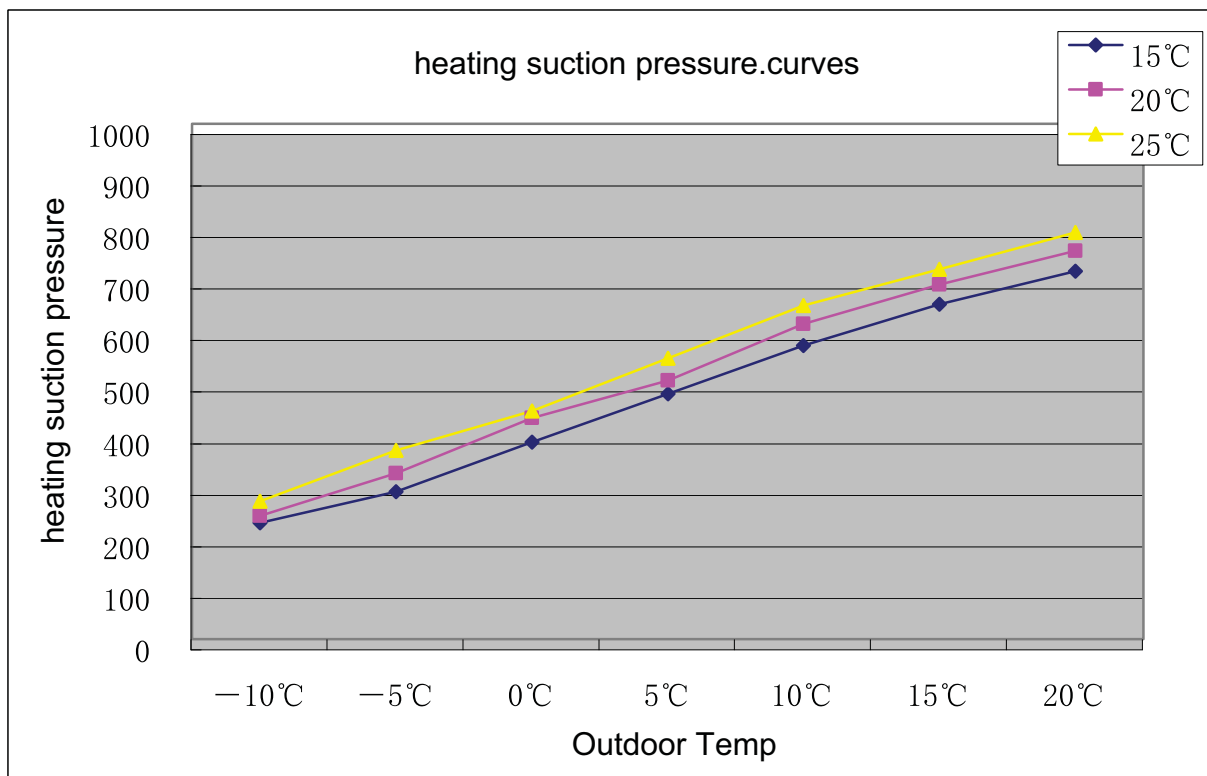

10 Sound level

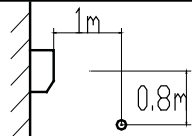
Model	Sound pressure level			Measuring location Location of microphone 	sound power level (cooling/heating)
	220V,50Hz				
	Cooling/heating				
	H	L	SL		
HSU-07 09L HEK03	37/37/37/37	33/33/33/33	29/29/29/29		37/37
HSU-12L HEK03	39/39	35/35	31/31		39/39

HSU-07 09L/HEK03

◆ INDOOR
◆ OUTDOOR

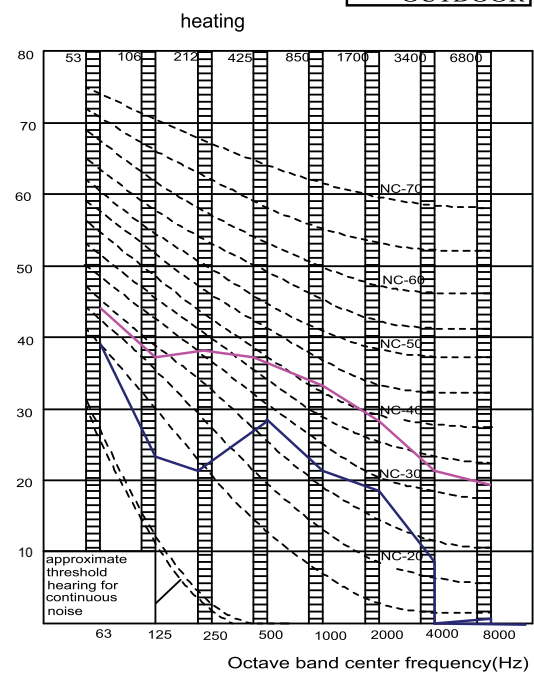
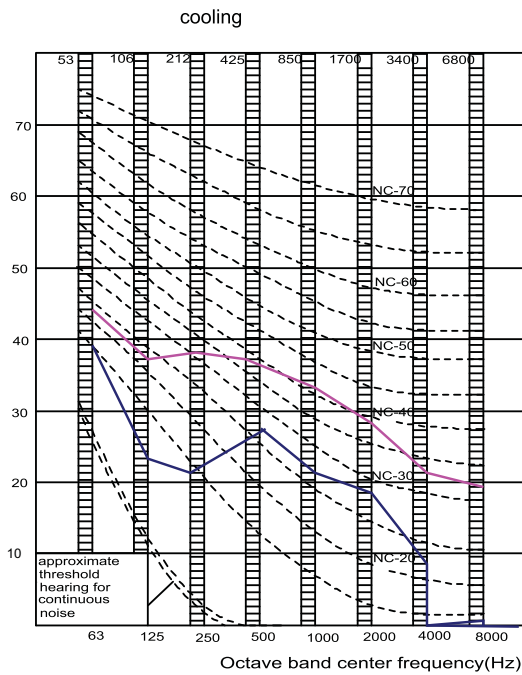

HSU-12L/HEK03

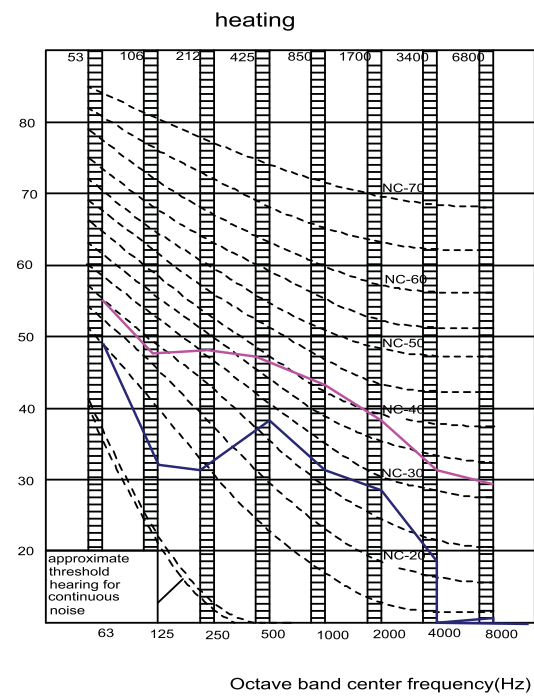
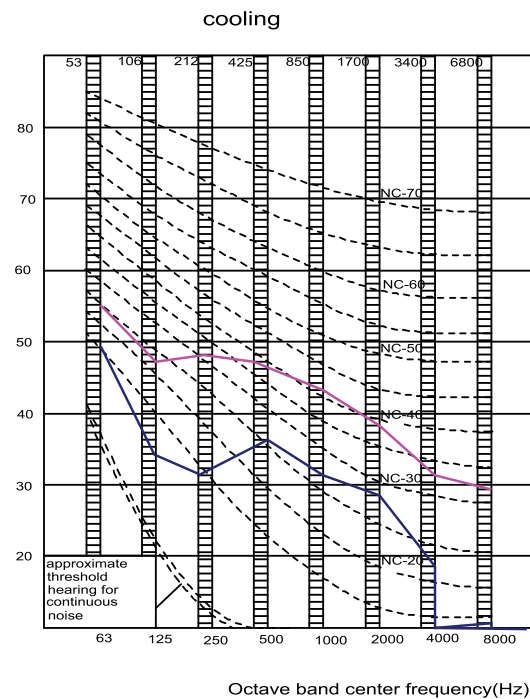

11 Accessories

Standard accessories

Standard name	HSU-07LEK03	HSU-07HEK03	HSU-09LEK03	HSU-09HEK03	HSU-12LEK03	HSU-12HEK03
Drain hose	1	1	1	1	1	1
Plastic bag	1	1	1	1	1	1
screw assembly	1	1	1	1	1	1
Air purifier	2	2	2	2	2	2
Change for fresh air tube (suit)	0	0	0	0	0	0
Mounting plate	1	1	1	1	1	1
Remote controller	1	1	1	1	1	1
Installation manual	1	1	1	1	1	1
Operation manual	1	1	1	1	1	1
R-03 dry battery	2	2	2	2	2	2
Steel nail	6	6	6	6	6	6
Plastic cap	4	4	4	4	4	4
Cover	1	1	1	1	1	1
Cushion	4	4	4	4	4	1
Pipe supporting plate	1	1	1	1	1	1
Drain-elbow	0	1	0	1	0	1

12 Control systems

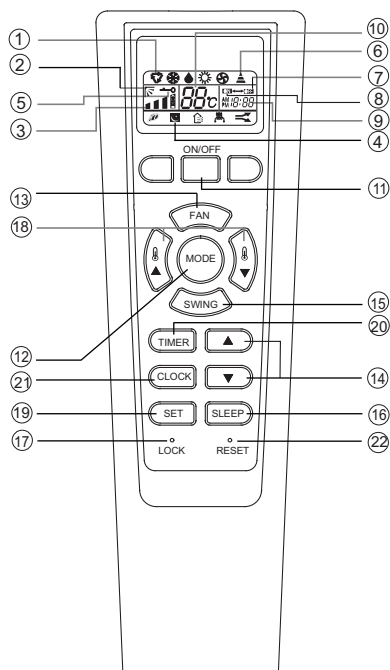

1. Mode display
 AUTO ❄️
 COOL ❄️
 DRY 🌧️
 HEAT ☀️
 FAN 🌀
2. SWING display
3. FAN SPEED display



4. SLEEP display
5. LOCK display
6. SIGNAL SENDING
7. TIMER OFF display
8. TIMER ON display
9. CLOCK display
10. TEMP display
11. POWER ON/OFF
Used for unit start and stop.
12. MODE
Used to select AUTO run, COOL, DRY, HEAT and FAN operation
13. FAN
Used to select fan speed LO, MED, HI, AUTO
14. HOUR
Used to set clock and timer setting.
15. SWING
Used to set auto fan direction.
16. SLEEP
Used to select sleep mode.
17. LOCK
Used to lock buttons and LCD display.
18. TEMP.SETTING
Used to select your desired temp.
19. SET
Used to confirm timer and clock settings.
20. TIMER
Used to select TIMER ON, TIMER OFF, TIMER ON-OFF
21. CLOCK
Used to set correct time
22. RESET
Used to reset the controller back to normal condition.
Used to operate the healthy function.

Clock set

When unit is started for the first time and after replacing batteries in remote controller, clock should be adjusted as follows:

Press CLOCK button, "AM" or "PM" flashes.

Press Δ or ∇ to set correct time. Each press will increase or decrease 1min. If the button is kept depressed, time will change quickly.

After time setting is confirmed, press SET, "AM" and "PM" stop flashing, while clock starts working.

NOTE: Cooling only unit do not have displays and functions related with heating

Hints

After replacing with new batteries, remote controller will conduct self-check, displaying all information on LCD. Then, it will become normal.

13 Center of gravity

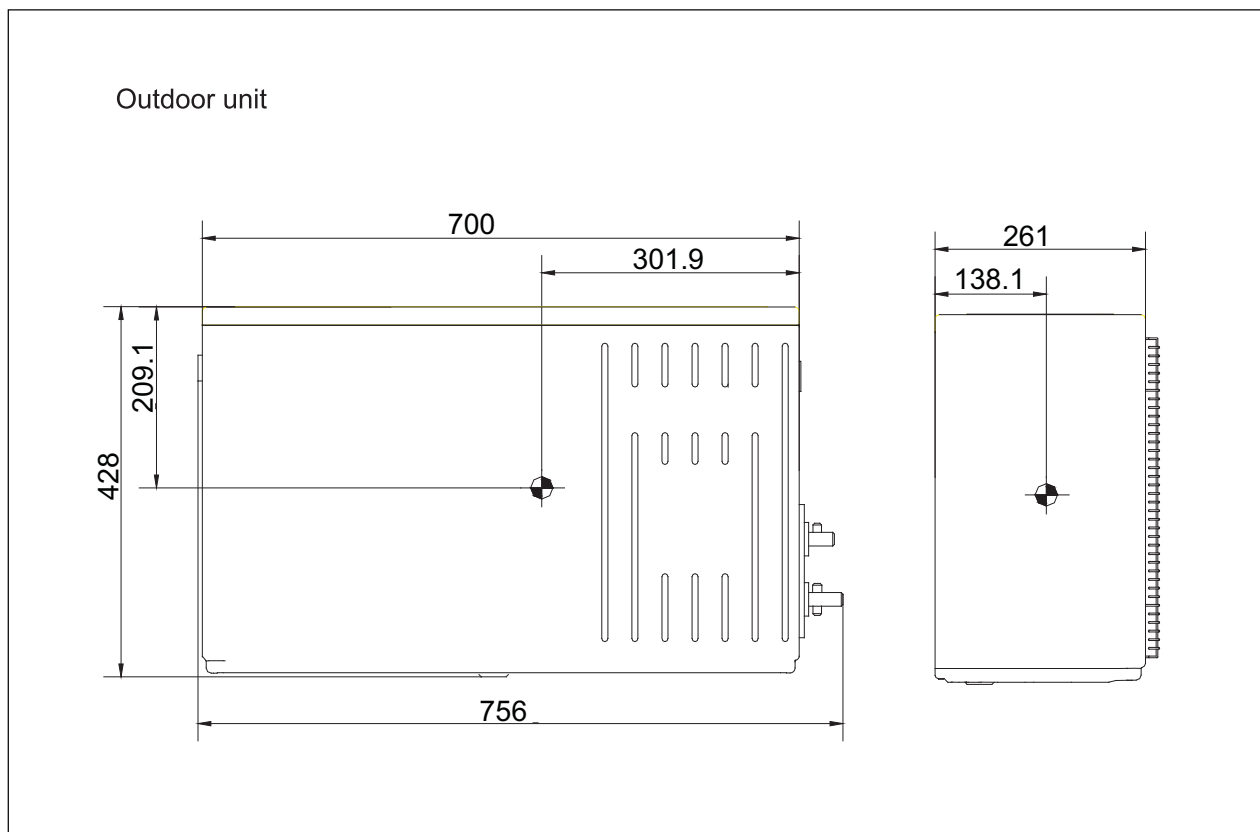
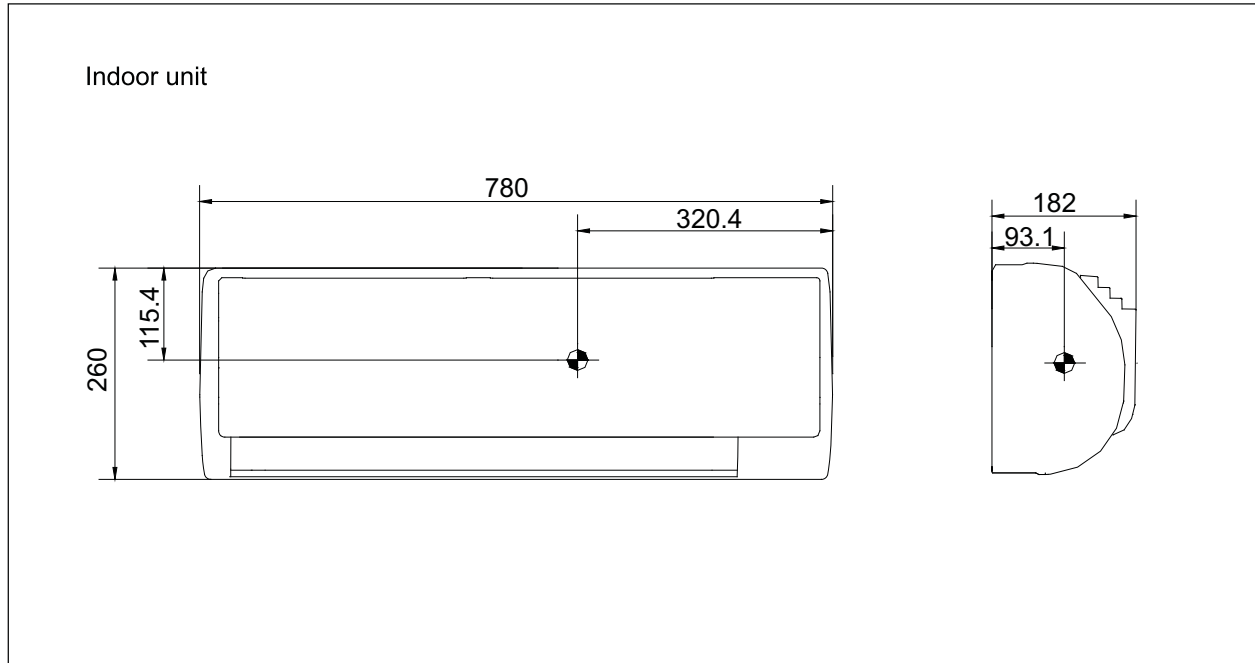

14 Installation

Indoor

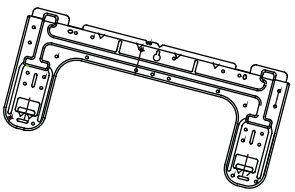

- How to attach the indoor unit.
Hook the claws of the bottom frame to the mounting plate.
If the claws are difficult to hook ,remove the front panel.
- How to remove the indoor unit.
Push up the marked area (at the lower part of the front panel) to release the the claws . If it is difficult to release ,remove the front panel .

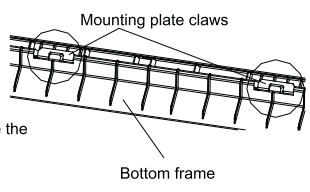

The mounting plate should be installed on a wall which can support the weight of the indoor unit.

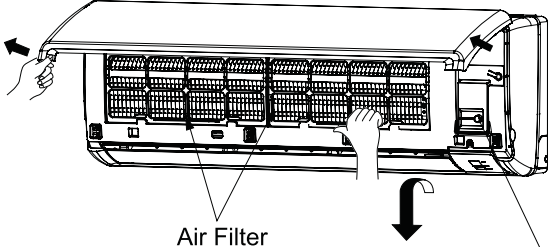

Air Filter

Piping hole pipe

Cut thermal insulation pipe to an appropriate length and wrap it with tape, making sure that no gap is left in the insulation pipe's cut line .

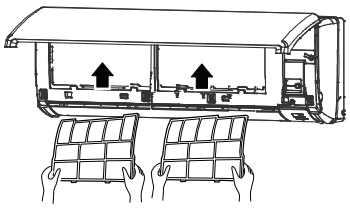

How to remove the air filter.

Open the inlet grille by pulling it upward.

Push up the filter's center tab slightly until it is released from the stopper, and remove the filter downward.

How to Attach the air filter.

Attach the filter correctly so that the "FRONT" indication is facing to the front. Make sure that the filter is completely fixed behind the stopper. If the right and left filters are not attached correctly, that may cause defects.

Close the inlet grille.

Service lid

The service lid is an open/close type

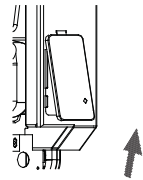

Remove the screws on the service lid.
Slide the service lid leftward.
Rotate the service lid upward

Outdoor

Model	07/09/12 class
Max.allowable length	7m/7m/10m
Max.allowable height	5m
Additional refrigerant required for refrigerant pipe exceeding 5m in length	20g/m
Gas pipe	O.D. 9.52 /9.52/12.7
Liquid pipe	O.D. 6.35

Arrangement of piping directions

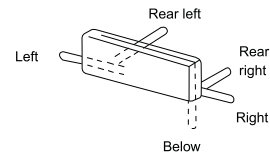

*Be sure to add the proper amount of additional refrigerant.
Failure to do so may result in reduced performance.

Optional parts for piping

Mark	Parts name
(A)	Non-adhesive tape
(B)	Adhesive tape
(C)	Saddle(L.S) with screws
(D)	Connecting electric cable for indoor and outdoor
(E)	Drain hose
(F)	Heating insulating material
(G)	Piping hole cover

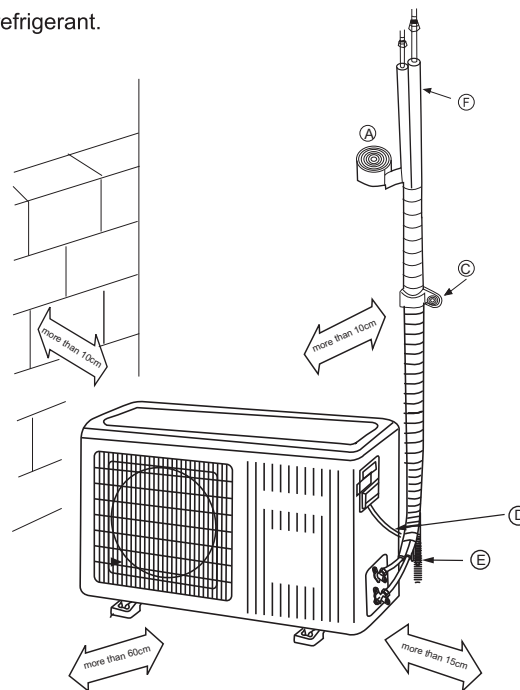

- ※ The marks from (A) to (G) in the figure are the parts numbers.
- ※ The distance between the indoor unit and the floor should be more than 2m.

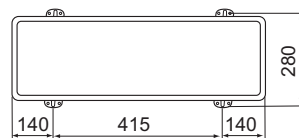

- Fix the unit to concrete or block with bolts (φ10mm) and nuts firmly and horizontally.
- When fitting the unit to wall surface, roof or rooftop, fix a supporter surely with nails or wires in consideration of earthquake and strong wind. The distance between the indoor unit and the floor should be more than 2m
- If vibration may affect the house, fix the unit by attaching a vibration-proof mat.

Sincere Forever



Haier Group

Haier Industrial Park, No.1, Haier Road

266101, Qingdao, China

E-mail: hractech@haier.com

Tel: +86 532 87636960

[Http://www.haier.com](http://www.haier.com)

Edited by: Wang Jing
Liu Xiujuan
Liu Jinlong

Signed by: Yang Bifei

Approved by: Wu hongjin